

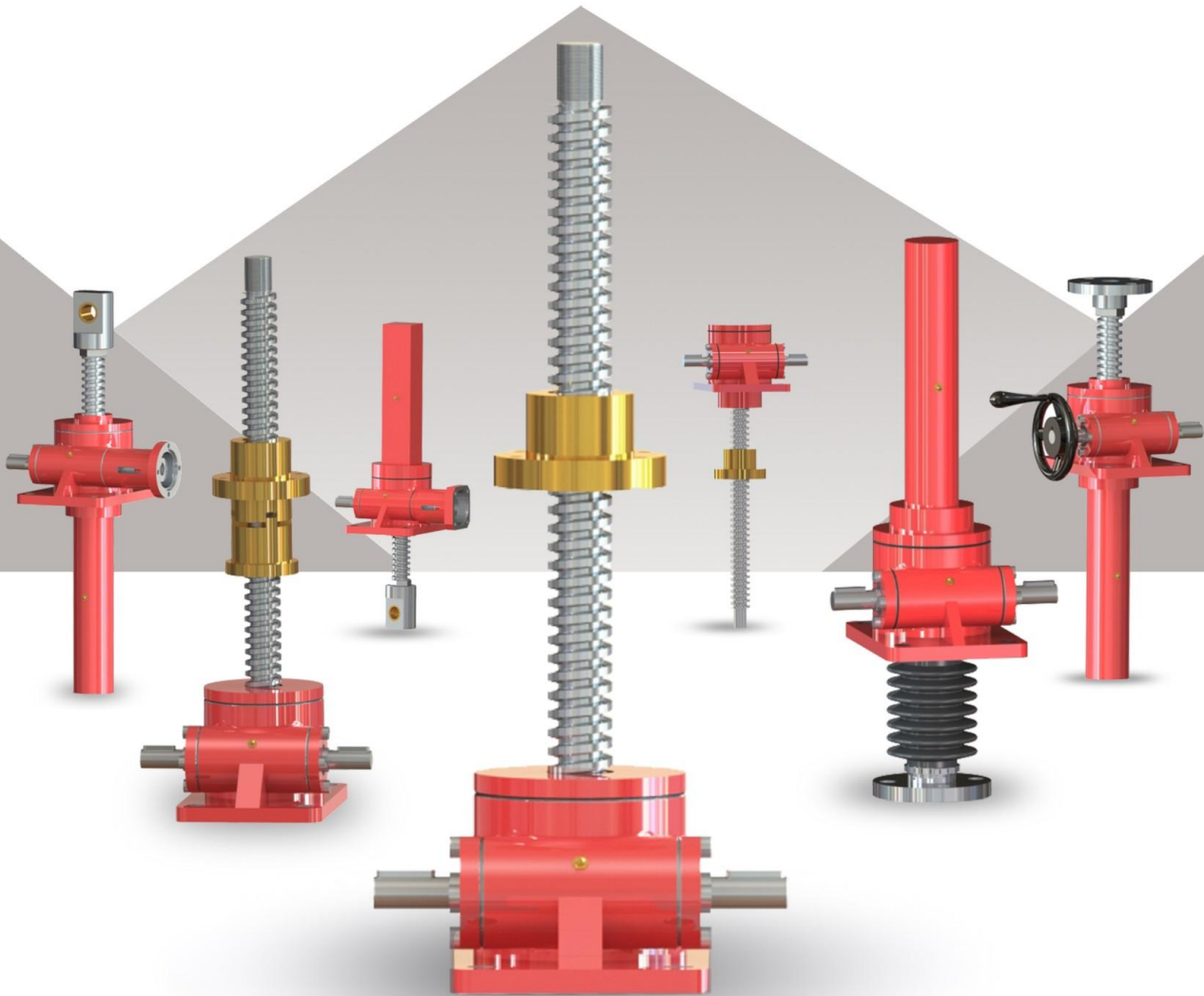

LINEAR MOTION



LUDE TRANSMISSION

SWL Series Screw Jack



LINEAR MOTION

Technical information

1 Permitted buckling force

Spindle dimensioning of the screw jack elements with compression force

The permitted buckling force for trapezoidal and ball-screw spindles can be verified using the following bend diagrams.

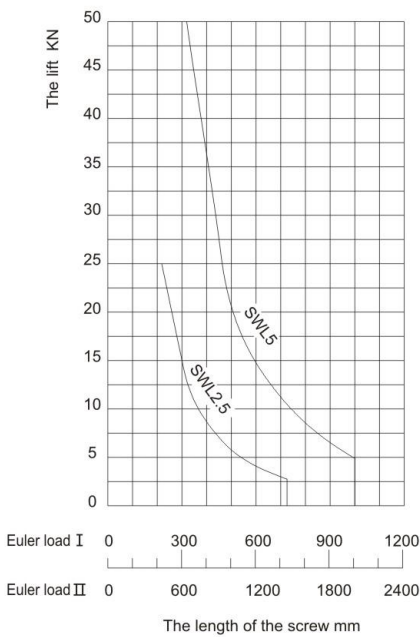
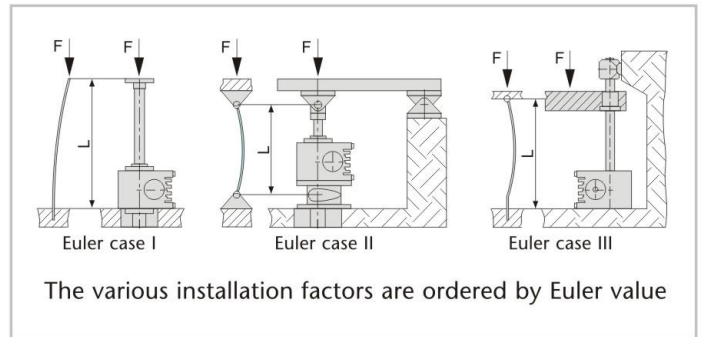

figure 1

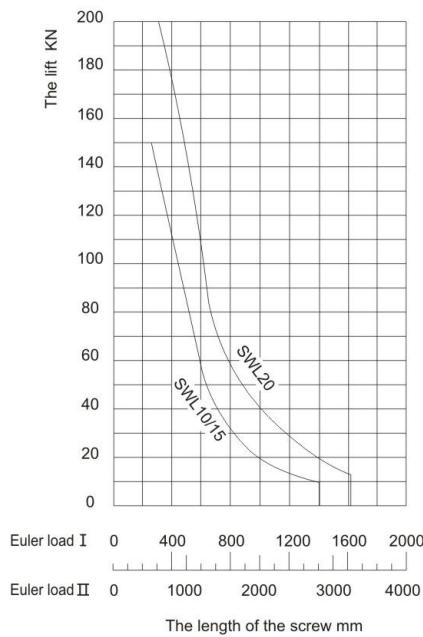

figure 2

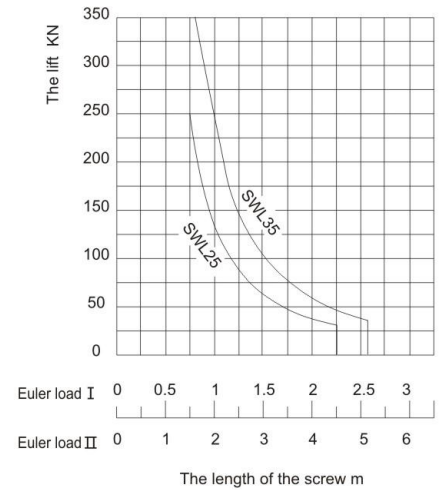

figure 3

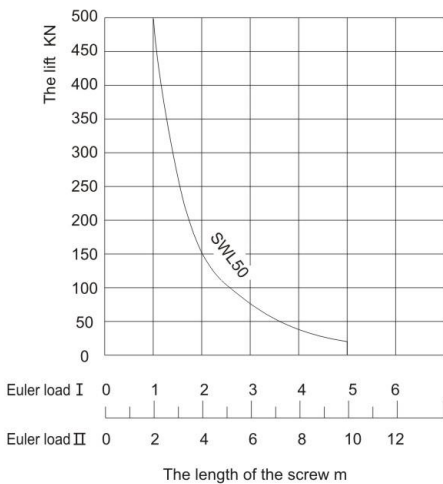

figure 4

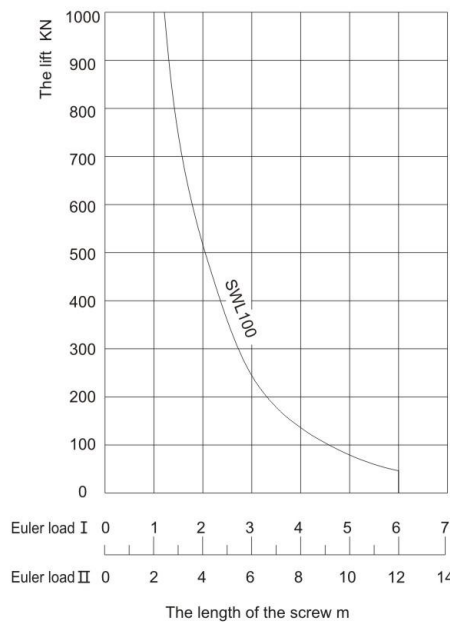

figure 5

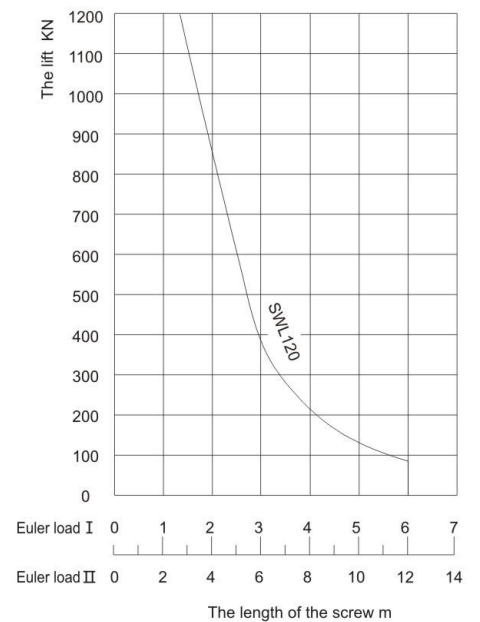

figure 6



2 Table of settings

2.1 SWL Worm gear screw jacks

Size		1	2,5	5	10
Max. lifting force	[kN]	10	25	50	100
Max. tension load	[kN]	10	25	50	99
Spindle Tr ¹⁾		24x4	30x6	40x7	58x12
Ratio P		6:1	6:1	6:1	8:1
Amount of lift per revolution for ratio P	[mm/per rev.]	0,67	1,0	1,167	1,5
Ratio M		24:1	24:1	24:1	24:1
Amount of lift per revolution for ratio M	[mm/per rev.]	0,17	0,25	0,292	0,50
Max. drive capacity ²⁾ at 20°C Ambient temp. and 20 % ED/hr	[kW]	0,35	0,65	1,15	2,7
Max. drive capacity ²⁾ at 20°C Ambient temp. and 10 % ED/hr	[kW]	0,55	0,9	1,65	3,85
Overall efficiency of ratio p	[%]	29	27	24	27
Rendement total Rapport p	[%]	20	19	16	17
Spindle efficiency rating	[%]	35	36	30	31
Torque, capacity, turning-speed at 20 % ED/hr and 20°C		See P30-P31			
Spindle torque at max. lifting power	[Nm]	18,4	60	153	468
Max. permitted drive-shaft torque	[Nm]	29,4	46,5	92	195
Max. permitted spindle length with compression load		See P34			
Housing material	[mm]	ductile	ductile		
Weight without screw jack and protection tube	[kg]	2,5	7,3	16,2	25
Spindle weight per 100 mm of lift	[kg]	0,23	0,45	0,82	1,67
Amounts of lubricant in transmission	[kg]	0,1	0,2	0,35	0,9
Mass moment of inertia ³⁾ P-ratio Type 1	[kg cm ²]	0,383	0,780	2,234	5,256
Mass moment of inertia ³⁾ P-ratio Type 2	[kg cm ²]	0,390	0,792	2,273	5,356
Mass moment of inertia ³⁾ M-ratio Type 1	[kg cm ²]	0,269	0,558	1,696	4,081
Mass moment of inertia ³⁾ M-ratio Type 2	[kg cm ²]	0,275	0,558	1,699	4,091

¹⁾ Also applies to Ku spindle.

²⁾ Max. permitted values for type 1 and Tr spindle. **Higher values are possible when using type 2 or Ku spindles.**

³⁾ referring to 100 mm spindle length



20	25	35	50	100	120	Size
200	250	350	500	1000	1200	Max. lifting force
166	250	350	500	1000	1200	Max. tension load
65x12	90x16	100x20	120x20	160x23	180x25	Spindle Tr ¹⁾
8:1	10 2/3:1	10 2/3:1	10 2/3:1	12:1	12:1	Ratio P
1,50	1,50	1,6 9	1,8 7	1,9 1	2,0 8	Amount of lift per revolution for ratio P
24:1	32:1	32:1	32:1	36:1	36:1	Ratio M
0,5	0,5	0,5 6	0,6 25	0,6 4	0,7	Amount of lift per revolution for ratio M
3,8	5,0	6,0	7,4	12,5	18,5	Max. drive capacity ²⁾ at 20°C Ambient temp. and 20 % ED/hr
5,4	7,2	8,6	10,4	17,5	26	Max. drive capacity ²⁾ at 20°C Ambient temp. and 10 % ED/hr
24	22	21	15	15	15	Overall efficiency of ratio p
17	15	14	10	9	-	Rendement total Rapport p
26	24	21	20	16	14	Spindle efficiency rating
See P30-P31						Torque, capacity, turning-speed at 20 % ED/hr and 20°C
1009	1725	2600	4235	11115	19850	Spindle torque at max. lifting power
280	480	705	840	2660	4260	Max. permitted drive-shaft torque
See P34						Max. permitted spindle length with compression load
ductile						Housing material
36	70,5	87	176	538	850	Weight without screw jack and protection tube
2,15	4,15	5,2	7,7	13,82	19,6	Spindle weight per 100 mm of lift
2	1,3	2,5	4,0	10,0	10,0	Amounts of lubricant in transmission
11,93	23,42	55,80	108,8	428,5	on request	Mass moment of inertia ³⁾ P-ratio Type 1
12,08	23,74	56,30	109,9	431,3	on request	Mass moment of inertia ³⁾ P-ratio Type 2
9,427	19,59	44,08	88,37	346,0	sur demande	Mass moment of inertia ³⁾ M-ratio Type 1
9,444	19,62	44,13	88,49	346,3	on request	Mass moment of inertia ³⁾ M-ratio Type 2



LINEAR MOTION

3 Performance tables (lifting elements with Tr spindle)

Turning speed, power requirement and permitted lifting speed for ratio N and L with single-threaded, lifting (Type 1) trapezoidal spindle. All performance data are expressed in terms of dynamic lifting force.

SWL 1T Tr24x4

n (1/min)	Lifting speed (m/min.)	F=10KN				F=8KN				F=6KN				F=4KN				F=3KN				F=2KN				F=1KN				
		P		M		P		M		P		M		P		M		P		M		P		M		P		M		
		P	M	Nm	Kw	Nm	Kw	Nm	Kw	Nm	Kw	Nm	Kw	Nm	Kw	Nm	Kw	Nm	Kw	Nm	Kw	Nm	Kw	Nm	Kw	Nm	Kw	Nm	Kw	Nm
1500	1	0.25	5.05	0.79	2.04	0.32	4.04	0.63	1.63	0.26	3.03	0.48	1.22	0.19	2.02	0.32	0.82	0.13	1.52	0.24	0.61	0.1	1.01	0.16	0.41	0.06	0.51	0.08	0.2	0.03
1000	0.67	0.17	5.05	0.53	2.04	0.21	4.04	0.42	1.63	0.17	3.03	0.32	1.22	0.13	2.02	0.21	0.82	0.09	1.52	0.16	0.61	0.06	1.01	0.11	0.41	0.04	0.51	0.05	0.2	0.02
750	0.5	0.13	5.05	0.4	2.04	0.16	4.04	0.32	1.63	0.13	3.03	0.24	1.22	0.1	2.02	0.16	0.82	0.06	1.52	0.12	0.61	0.05	1.01	0.08	0.41	0.03	0.51	0.04	0.2	0.02
600	0.4	0.1	5.05	0.32	2.04	0.13	4.04	0.25	1.63	0.1	3.03	0.19	1.22	0.08	2.02	0.13	0.82	0.05	1.52	0.1	0.61	0.04	1.01	0.06	0.41	0.03	0.51	0.03	0.2	0.01
500	0.33	0.08	5.05	0.26	2.04	0.11	4.04	0.21	1.63	0.09	3.03	0.16	1.22	0.06	2.02	0.11	0.82	0.04	1.52	0.08	0.61	0.03	1.01	0.05	0.41	0.02	0.51	0.03	0.2	0.01
300	0.2	0.05	5.05	0.16	2.04	0.06	4.04	0.13	1.63	0.05	3.03	0.1	1.22	0.04	2.02	0.06	0.82	0.03	1.52	0.05	0.61	0.02	1.01	0.03	0.41	0.01	0.51	0.02	0.2	0.01
200	0.13	0.03	5.05	0.11	2.04	0.04	4.04	0.08	1.63	0.03	3.03	0.06	1.22	0.03	2.02	0.04	0.82	0.02	1.52	0.03	0.61	0.01	1.01	0.02	0.41	0.01	0.51	0.01	0.2	0
100	0.07	0.02	5.05	0.05	2.04	0.02	4.04	0.04	1.63	0.02	3.03	0.03	1.22	0.01	2.02	0.02	0.82	0.01	1.52	0.02	0.61	0.01	1.01	0.01	0.41	0	0.51	0.01	0.2	0
50	0.03	0.01	5.05	0.03	2.04	0.01	4.04	0.02	1.63	0.01	3.03	0.02	1.22	0.01	2.02	0.01	0.82	0	1.52	0.01	0.61	0	1.01	0.01	0.41	0	0.51	0	0.2	0

SWL2.5T Tr30x6

n (1/min)	Lifting speed (m/min.)	F=25KN				F=20KN				F=15KN				F=10KN				F=5KN				F=2.5KN				F=1KN				
		P		M		P		M		P		M		P		M		P		M		P		M		P		M		
		P	M	Nm	Kw	Nm	Kw	Nm	Kw	Nm	Kw	Nm	Kw	Nm	Kw	Nm	Kw	Nm	Kw	Nm	Kw	Nm	Kw	Nm	Kw	Nm	Kw	Nm	Kw	Nm
1500	1.5	0.38	17.3	2.72	7.11	1.12	13.8	2.17	5.68	0.89	10.4	1.63	4.26	0.67	6.92	1.09	2.84	0.45	3.46	0.54	1.42	0.22	1.73	0.27	0.71	0.11	0.69	0.11	0.28	0.04
1000	1	0.25	17.3	1.81	7.11	0.74	13.8	1.45	5.68	0.6	10.4	1.09	4.26	0.45	6.92	0.72	2.84	0.3	3.46	0.36	1.42	0.15	1.73	0.18	0.71	0.07	0.69	0.07	0.28	0.03
750	0.75	0.19	17.3	1.36	7.11	0.56	13.8	1.09	5.68	0.45	10.4	0.82	4.26	0.33	6.92	0.54	2.84	0.22	3.46	0.27	1.42	0.11	1.73	0.14	0.71	0.06	0.69	0.05	0.28	0.02
600	0.6	0.15	17.3	1.09	7.11	0.45	13.8	0.87	5.68	0.36	10.4	0.65	4.26	0.27	6.92	0.43	2.84	0.18	3.46	0.22	1.42	0.09	1.73	0.11	0.71	0.05	0.69	0.04	0.28	0.02
500	0.5	0.13	17.3	0.91	7.11	0.37	13.8	0.72	5.68	0.3	10.4	0.54	4.26	0.22	6.92	0.36	2.84	0.15	3.46	0.18	1.42	0.07	1.73	0.09	0.71	0.04	0.69	0.04	0.28	0.01
300	0.3	0.08	17.3	0.54	7.11	0.22	13.8	0.43	5.68	0.18	10.4	0.33	4.26	0.13	6.92	0.22	2.84	0.09	3.46	0.11	1.42	0.04	1.73	0.05	0.71	0.02	0.69	0.02	0.28	0.01
200	0.2	0.05	17.3	0.36	7.11	0.15	13.8	0.29	5.68	0.12	10.4	0.22	4.26	0.09	6.92	0.14	2.84	0.06	3.46	0.07	1.42	0.03	1.73	0.04	0.71	0.02	0.69	0.01	0.28	0.01
100	0.1	0.03	17.3	0.18	7.11	0.07	13.8	0.14	5.68	0.06	10.4	0.11	4.26	0.04	6.92	0.07	2.84	0.03	3.46	0.04	1.42	0.01	1.73	0.02	0.71	0.01	0.69	0.01	0.28	0
50	0.05	0.01	17.3	0.09	7.11	0.04	13.8	0.07	5.68	0.03	10.4	0.05	4.26	0.02	6.92	0.04	2.84	0.01	3.46	0.02	1.42	0.01	1.73	0.01	0.71	0	0.69	0	0.28	0

SWL 5T Tr40x7

n (1/min)	Lifting speed (m/min.)	F=50KN				F=40KN				F=30KN				F=20KN				F=10KN				F=5KN				F=2.5KN				
		P		M		P		M		P		M		P		M		P		M		P		M		P		M		
		P	M	Nm	Kw	Nm	Kw	Nm	Kw	Nm	Kw	Nm	Kw	Nm	Kw	Nm	Kw	Nm	Kw	Nm	Kw	Nm	Kw	Nm	Kw	Nm	Kw	Nm	Kw	Nm
1500	1.75	0.44	44.2	6.94	19.3	3.04	35.4	5.56	15.5	2.43	26.5	4.17	11.6	1.82	17.7	2.78	7.74	1.22	8.84	1.39	3.87	0.61	4.42	0.69	1.93	0.3	2.21	0.35	0.97	0.15
1000	1.17	0.29	44.2	4.63	19.3	2.03	35.4	3.7	15.5	1.62	26.5	2.78	11.6	1.22	17.7	1.85	7.74	0.81	8.84	0.93	3.87	0.41	4.42	0.46	1.93	0.2	2.21	0.23	0.97	0.1
750	0.88	0.22	44.2	3.47	19.3	1.52	35.4	2.78	15.5	1.22	26.5	2.08	11.6	0.91	17.7	1.39	7.74	0.61	8.84	0.69	3.87	0.3	4.42	0.35	1.93	0.15	2.21	0.17	0.97	0.08
600	0.7	0.18	44.2	2.78	19.3	1.22	35.4	2.22	15.5	0.97	26.5	1.67	11.6	0.73	17.7	1.11	7.74	0.49	8.84	0.56	3.87	0.24	4.42	0.28	1.93	0.12	2.21	0.14	0.97	0.06
500	0.58	0.15	44.2	2.31	19.3	1.01	35.4	1.85	15.5	0.81	26.5	1.39	11.6	0.61	17.7	0.93	7.74	0.41	8.84	0.46	3.87	0.2	4.42	0.23	1.93	0.1	2.21	0.12	0.97	0.05
300	0.35	0.09	44.2	1.39	19.3	0.61	35.4	1.11	15.5	0.49	26.5	0.83	11.6	0.36	17.7	0.56	7.74	0.24	8.84	0.28	3.87	0.12	4.42	0.14	1.93	0.06	2.21	0.07	0.97	0.03
200	0.23	0.06	44.2	0.93	19.3	0.41	35.4	0.74	15.5	0.32	26.5	0.56	11.6	0.24	17.7	0.37	7.74	0.16	8.84	0.19	3.87	0.08	4.42	0.09	1.93	0.04	2.21	0.05	0.97	0.02
100	0.12	0.03	44.2	0.46	19.3	0.2	35.4	0.37	15.5	0.16	26.5	0.28	11.6	0.12	17.7	0.19	7.74	0.08	8.84	0.09	3.87	0.04	4.42	0.05	1.93	0.02	2.21	0.02	0.97	0.01
50	0.06	0.01	44.2	0.23	19.3	0.1	35.4	0.19	15.5	0.08	26.5	0.14	11.6	0.06	17.7	0.09	7.74	0.04	8.84	0.05	3.87	0.02	4.42	0.02	1.93	0.01	2.21	0.01	0.97	0.01

SWL 10T Tr58x12

n (1/min)	Lifting speed (m/min.)	F=100KN				F=80KN				F=60KN				F=40KN				F=20KN				F=10KN				F=5KN				
		P		M		P		M		P		M		P		M		P		M		P		M		P		M		
		P	M	Nm	Kw	Nm	Kw	Nm	Kw	Nm	Kw	Nm	Kw	Nm	Kw	Nm	Kw	Nm	Kw	Nm	Kw	Nm	Kw	Nm	Kw	Nm	Kw	Nm	Kw	Nm
1500	2.25	0.75	104	16.3	53.1	8.33	83	13	42.4	6.67	62.3	9.78	31.8	5	41.5	6.52	21.2	3.33	20.8	3.26	10.6	1.67	10.4	1.63	5.31	0.83	5.19	0.82	2.65	0.42
1000	1.5	0.5	104	10.9	53.1	5.56	83	8.7	42.4	4.44	62.3	6.52	31.8	3.33	41.5	4.35	21.2	2.22	20.8	2.17	10.6	1.11	10.4	1.09	5.31	0.56	5.19	0.54	2.65	0.28
750	1.13	0.38	104	8.15	53.1	4.17	83	6.52	42.4	3.33	62.3	4.89	31.8	2.5	41.5	3.26	21.2	1.67	20.8	1.63	10.6	0.83	10.4	0.82	5.31	0.42	5.19	0.41	2.65	0.21
600	0.9	0.3	104	6.52	53.1	3.33	83	5.22	42.4	2.67	62.3	3.91	31.8	2	41.5	2.61	21.2	1.33	20.8	1.3	10.6	0.67	10.4	0.65	5.31	0.33	5.19	0.33	2.65	0.17
500	0.75	0.25	104	5.43	53.1	2.78	83	4.35	42.4	2.22	62.3	3.26	31.8	1.67	41.5	2.17	21.2	1.11	20.8	1.09	10.6	0.56	10.4	0.54	5.31	0.28	5.19	0.27	2.65	0.14
300	0.45	0.15	104	3.26	53.1	1.67	83	2.61	42.4	1.33	62.3	1.96	31.8	1	41.5	1.3	21.2	0.67	20.8	0.65	10.6	0.33	10.4	0.33	5.31	0.17	5.19	0.16	2.65	0.08
200	0.3	0.1	104	2.17	53.1	1.11	83	1.74	42.4	0.89	62.3	1.3	31.8	0.67	41.5	0.87	21.2	0.44	20.8	0.43	10.6	0.22	10.4	0.22	5.31	0.11	5.19	0.11	2.65	0.06
100	0.15	0.05	104	1.09	53.1	0.56	83	0.87	42.4	0.44	62.3	0.65	31.8	0.33	41.5	0.43	21.2	0.22	20.8	0.22	10.6	0.11	10.4	0.11	5.31	0.06	5.19	0.05	2.65	0.03



LINEAR MOTION

SWL 20T Tr65x12

Table with columns for lifting speed (n, m/min), force (F=250KN to F=50KN), and torque (Nm, Kw) for static and dynamic conditions.

SWL 25T Tr90x16

Table with columns for lifting speed (n, 1/min), force (F=250KN to F=50KN), and torque (Nm, Kw) for static and dynamic conditions.

SWL 35T Tr100x20

Table with columns for lifting speed (n, 1/min), force (F=350KN to F=50KN), and torque (Nm, Kw) for static and dynamic conditions.

SWL 50T Tr120x20

Table with columns for lifting speed (n, 1/min), force (F=500KN to F=100KN), and torque (Nm, Kw) for static and dynamic conditions.

SWL 100T Tr160x23

Table with columns for lifting speed (n, 1/min), force (F=1000KN to F=100KN), and torque (Nm, Kw) for static and dynamic conditions.

SWL 120T Tr180x25

Table with columns for lifting speed (n, 1/min), force (F=1200KN to F=100KN), and torque (Nm, Kw) for static and dynamic conditions.

20% ED / 1hr or 30% ED / 10min. and ambient temperature 20°C and ambient temp. 20°C

static only (dynamic not permitted)

10% ED/1hr and ambient temperature 20°C



3.1 Technical information

3.1.1 Lifting-element efficiency ratings “ η ”

Formula: $\eta_{HE} = \eta_G * \eta_{Sp}$

3.1.1.1 SWL range

Overall efficiency ratings η_{HE} of SHE gears and spindles with grease lubrication

Size	1P	2.5P	5P	10P	20P	25P	35P	50P	100P	120P
η_{HE}	0.29	0.27	0.24	0.27	0.24	0.22	0.21	0.15	0.15	0.16
Size	1M	2.5M	5M	10M	20M	25M	35M	50M	100M	120M
η_{HE}	0.20	0.19	0.16	0.17	0.17	0.15	0.14	0.10	0.09	-

Gear efficiency ratings η_G of SHE gears with grease lubrication (without spindles)

Size	1P	2.5P	5P	10P	15P	20P	25P	35P	50P	100P	120P
η_{HE}	0.68	0.68	0.66	0.66	0.66	0.64	0.61	0.62	0.5	0.53	0.56
Size	1M	2.5M	5M	10M	15M	20M	25M	35M	50M	100M	120M
η_{HE}	0.48	0.47	0.43	0.42	0.42	0.46	0.41	0.42	0.34	0.32	0.32

Overall efficiency ratings η_{HE} of type 2 gears with oil lubrication and spindles with grease lubrication

Size	1P	2.5P	5P	10P	20P	25P	35P	50P	100P	120P
Turning speed [rpm]										
1500	0.355	0.283	0.257	0.290	0.273	0.262	0.248	0.281	0.210	0.220
1000	0.347	0.279	0.252	0.285	0.268	0.257	0.243	0.215	0.206	0.215
750	0.342	0.276	0.249	0.282	0.266	0.253	0.240	0.212	0.204	0.210
500	0.334	0.272	0.245	0.277	0.262	0.249	0.236	0.208	0.200	0.205
300	0.325	0.267	0.241	0.272	0.257	0.243	0.231	0.204	0.196	0.200
100	0.373	0.257	0.231	0.261	0.247	0.233	0.222	0.195	0.187	0.195
50	0.309	0.251	0.225	0.255	0.242	0.226	0.216	0.190	0.182	0.188
Size	1M	2.5M	5M	10M	20M	25M	35M	50M	100M	120M
Turning speed [rpm]										
1500	0.260	0.214	0.188	0.236	0.225	0.210	0.204	0.181	0.176	-
1000	0.246	0.206	0.180	0.227	0.217	0.200	0.195	0.174	0.169	-
750	0.237	0.201	0.175	0.222	0.212	0.194	0.189	0.169	0.164	-
500	0.224	0.194	0.168	0.215	0.205	0.187	0.183	0.162	0.157	-
300	0.212	0.187	0.161	0.207	0.198	0.179	0.175	0.155	0.150	-
100	0.195	0.172	0.146	0.191	0.183	0.164	0.160	0.142	0.137	-
50	0.190	0.164	0.138	0.183	0.175	0.155	0.152	0.135	0.130	-



LINEAR MOTION

3.1.1.2 Spindle efficiency ratings Sp (steel/bronze lubricated)

Size	SWL1	SWL2.5	SWL5	SWL10	SWL20	SWL25	SWL35	SWL50	SWL100	SWL120
Tr spindle	24×4	30×6	40×7	58×12	65×12	90×16	100×20	120×20	160×23	180×25
Spindle efficiency rating[%]	0.35	0.36	0.30	0.31	0.26	0.24	0.21	0.20	0.16	0.14

3.1.2 Critical spindle turning speed

The critical turning speed (only configuration type 2) is dependent on the spindle diameter, the spindle length and the spindle bearing (see case 1-4).

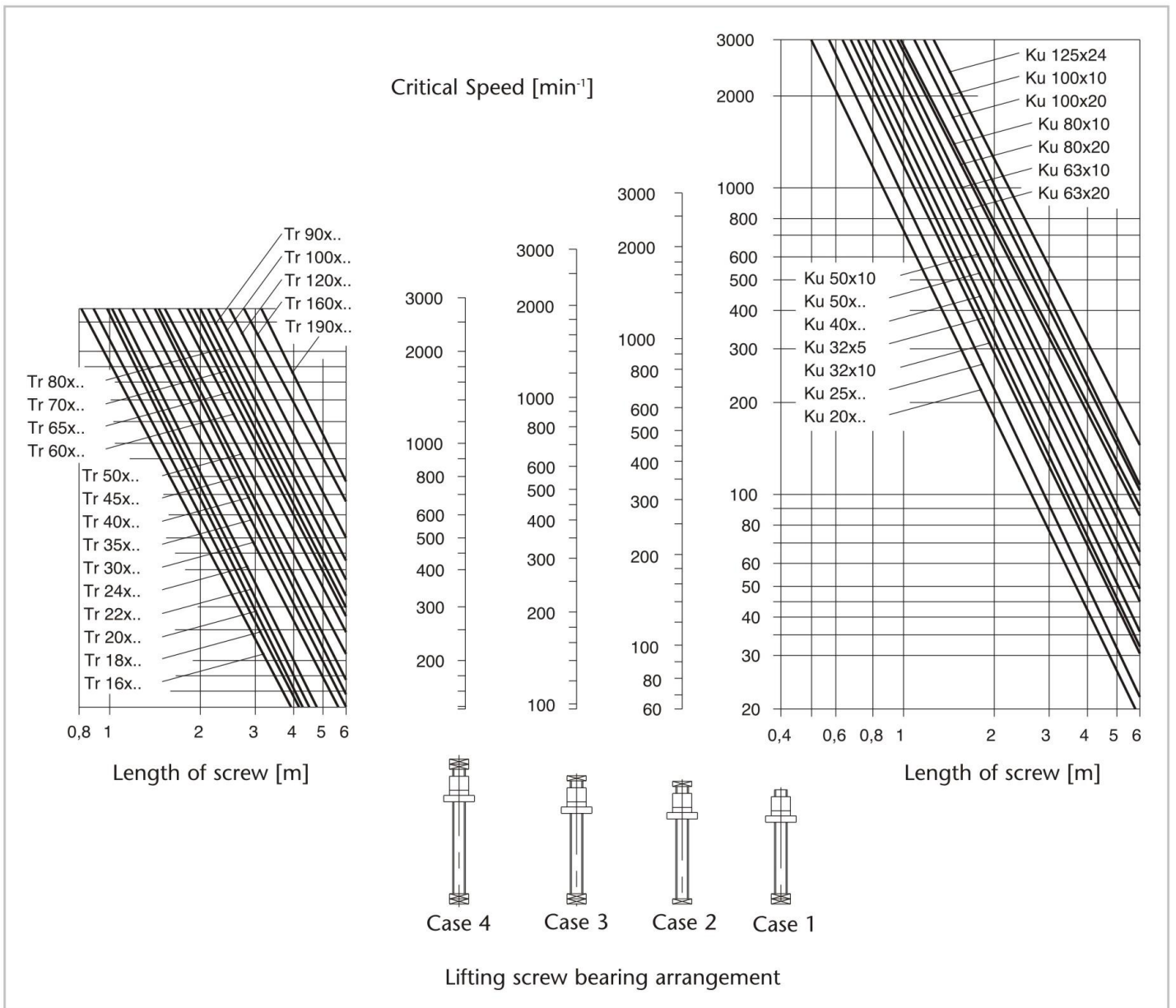

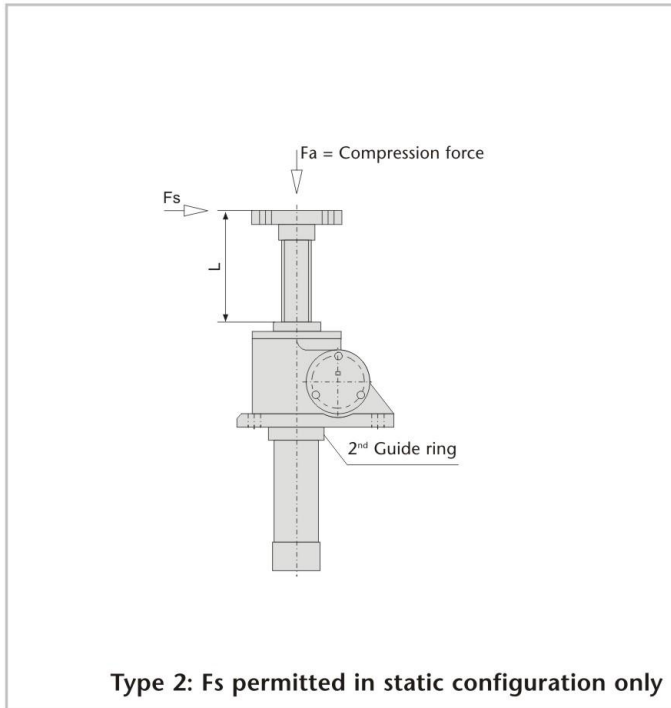

3.1.3 Permitted lateral force on spindle

The permitted lateral force (F_s) on the spindle depends on the axial force (F_a), the diameter of the spindle (d) and the length of the spindle L . As compression and buckling force exercise negative influence, these factors were taken into account when determining this permitted lateral force (F_s). The maximum length of the spindle (L) is limited by the value generally used in mechanical engineering applications: "unguided spindle length = 4x free clamping length". Lateral force on the spindle is only permitted on screw jacks fitted with two guide rings. Lateral forces on spindles or travelling nuts exercise a reinforced edge compression on the movement thread, leading to increased wear and a shortened service life.

The relationship between the allowable radial force F_s and the axial force F_a of the lead screw and the stroke

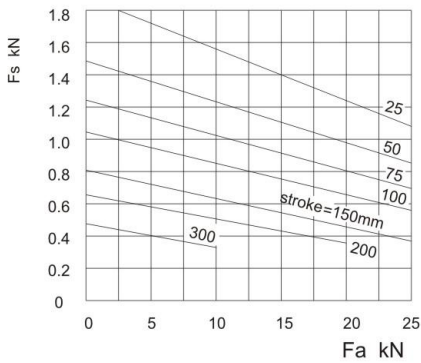

figure 5 SWL2.5

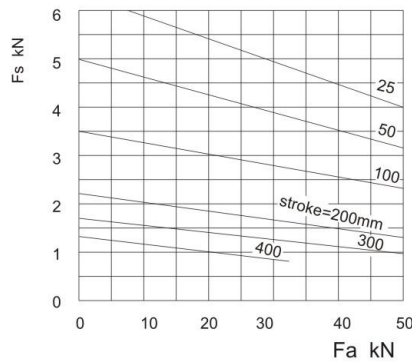

figure 6 SWL5

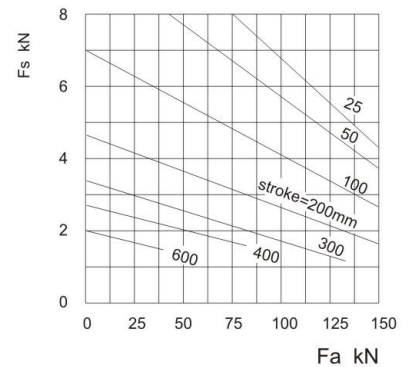

figure 7 SWL10/15

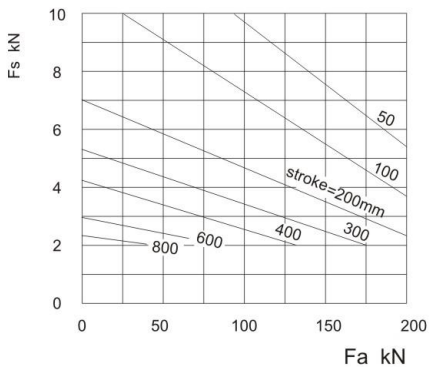

figure 8 SWL20

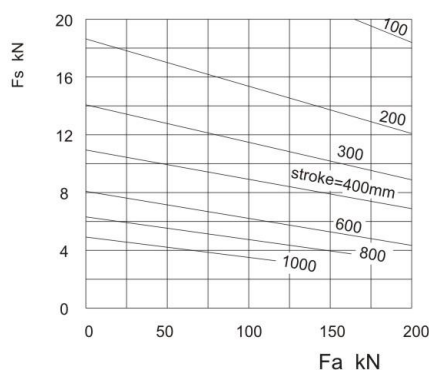

figure 9 SWL25

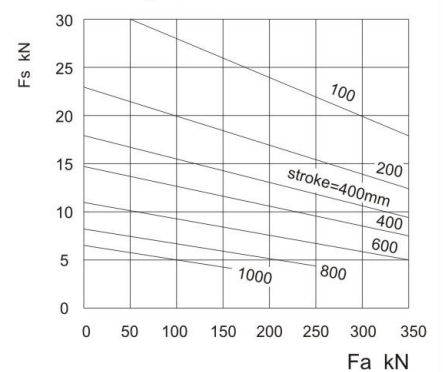

figure 10 SWL35



LINEAR MOTION

3.2 Allowable radial force of the input shaft

1. The worm shaft is extended. Due to the radial force F_r generated by the gear, sprocket or pulley, the maximum allowable force is related to the length and type. See the maximum radial force and torque allowed at 1/2.

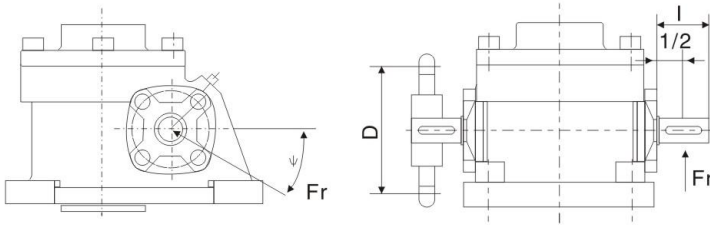

Size	F_{rmax} N	Mt_{max} N·m
SWL1/1M	160	6.6
SWL2.5/2.5M	350	18
SWL5/5M	750	44.2
SWL10/10M/15/15M	1000	108
SWL20/20M	1300	182
SWL25/25M	2000	314
SWL35/35M	2300	398

Note: The parameters in the table are calculated as $\psi \approx 30^\circ$ or 330° .

2. The minimum diameter of the gear or pulley:

$$D_{min} = 19100 \times \frac{P}{F_{max} n} = \frac{2M_1}{F_{max}}$$

Where: D_{min} --the minimum diameter of the gear or pulley, m;

P --drive power, KW;

F_{max} --maximum radial force, N;

n --worm speed, r/min;

M_1 --drive torque, N·m

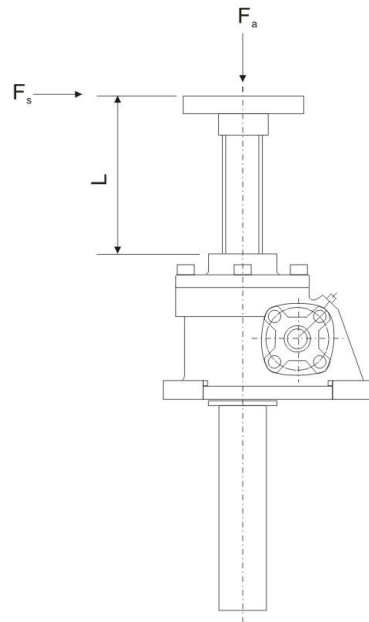



SWL-1A

SWL-1B

Example :

SWL 2.5 M - 1 A II - 300 - FZ - C
 1 2 3 4 5 6 7 8 9

1. SWL: serial number, SWL series - worm gear + T type screw lift; SWLB worm gear + ball screw lift;
2. 2.5: model, with the static load capacity of the lift as the model; mainly: 1, 2.5, 5, 10, 20, 25, 35, 50, 100, 120;
3. M: lifting speed, mainly refers to the deceleration ratio of worm gear pair; M: slow; P: fast;
4. 1: Structural model; Type 1: nut for rotary motion, screw for axial movement (products shown on this page are type I);
Type 2: screw for rotary motion, nut for axial movement;
5. A: assembly type; type A: the screw (or nut) moves up (mounting surface); type B: the screw (or nut) moves down (mounting surface);
6. II: screw head type: 1 type screw head is divided into I type (cylindrical type), type II (flange type), type III (thread type), type IV (flat head type);
2 type screw head is divided into I type (cylindrical type) and type III (thread type);
7. 300: lifting stroke; customer customization;
8. FZ: anti-rotation and protection of the screw;
Type 1 structure has basic type, anti-rotation type (F-key anti-rotation) and protective cover type (Z steel pipe protection - passive side, X telescopic tube protection - active side, Q both);
Type 2 structure has basic type and protective cover type (X telescopic tube protection - active side);
9. C: the axis points to A; B; C; D; E;



SWL1 type 1 structure (screw lifting type)

1A Upright translating screw

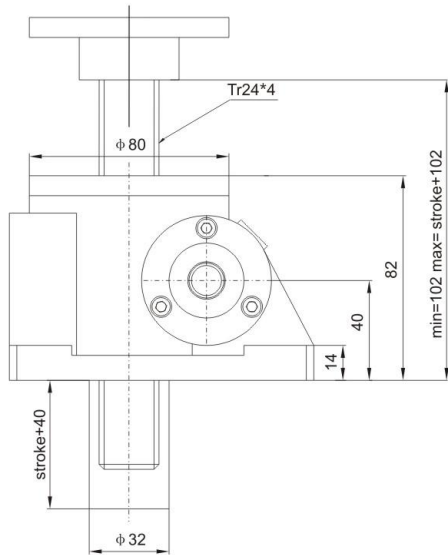

1B Inverted translating screw

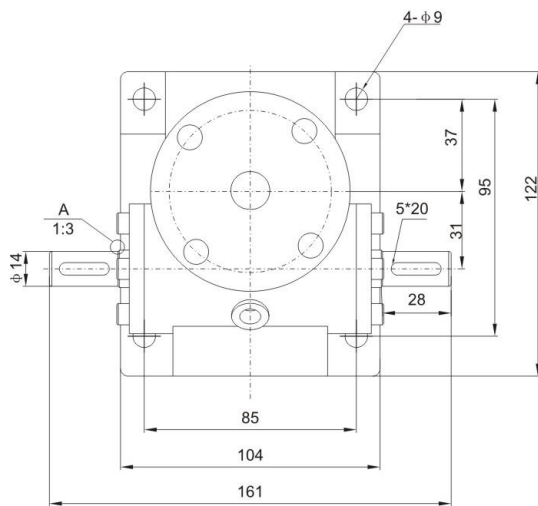
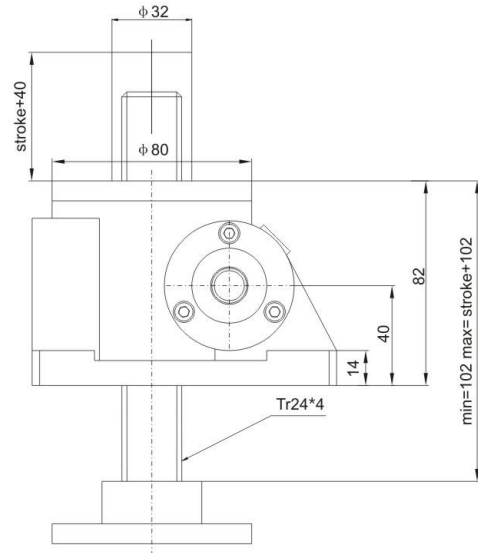

Screw head optional

Type I



Type II

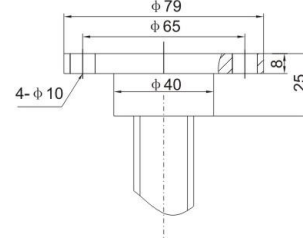

Type III

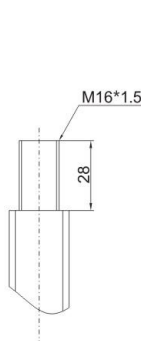

Type IV

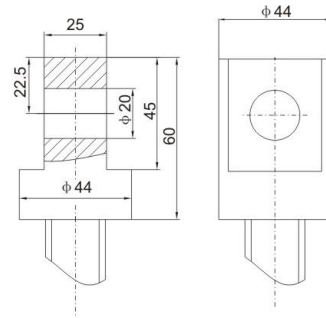

A
1:3



Shaft Direction

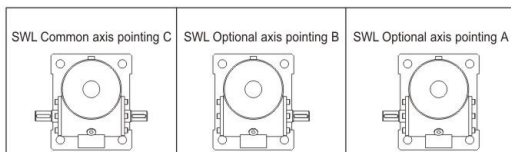



SWL5 type 1 structure (screw lifting type)

1A Upright translating screw

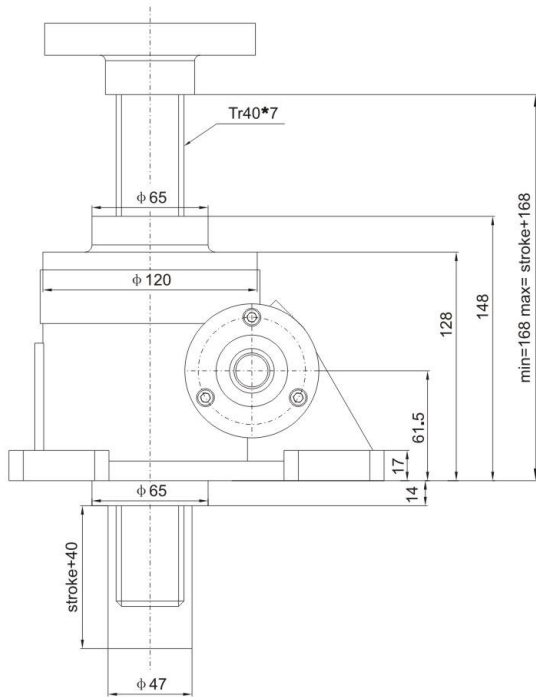

1B Inverted translating screw

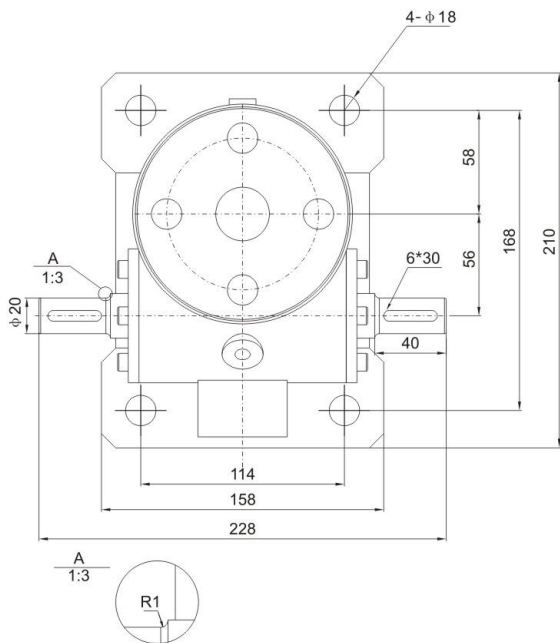
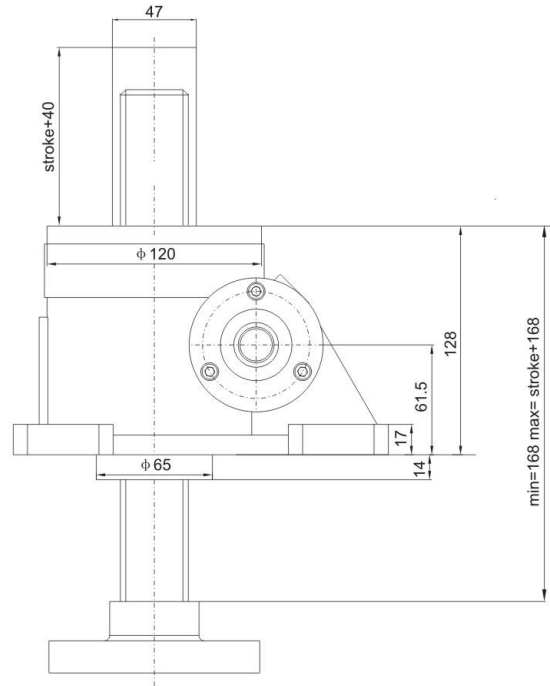

Screw head optional

Type I

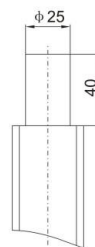

Type II

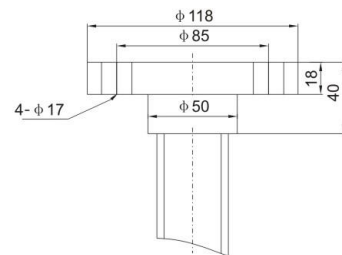

Type III



Type IV

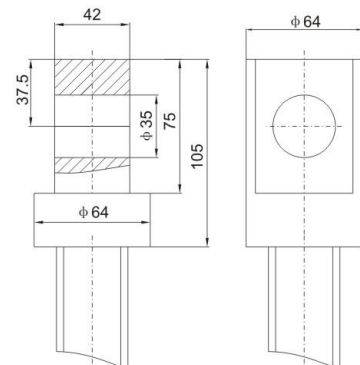

Shaft Direction

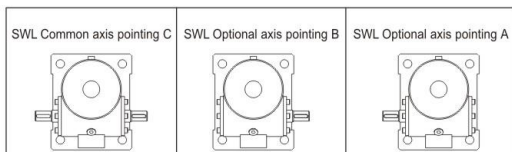



SWL10 type 1 structure (screw lifting type)

1A Upright translating screw

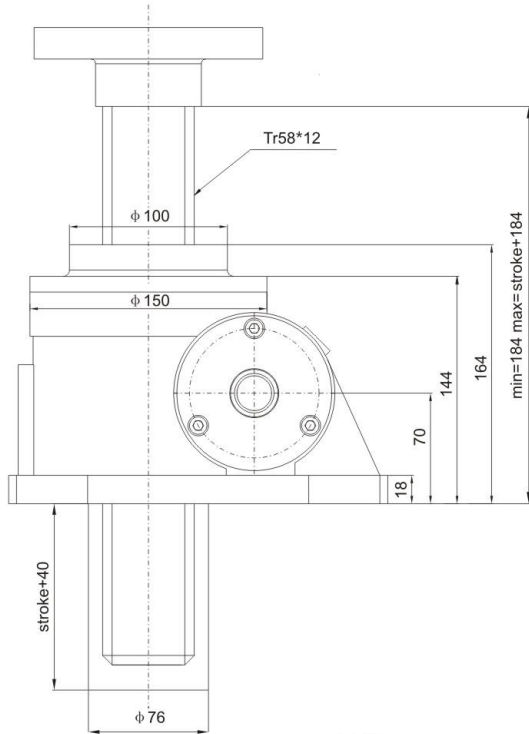

1B Inverted translating screw

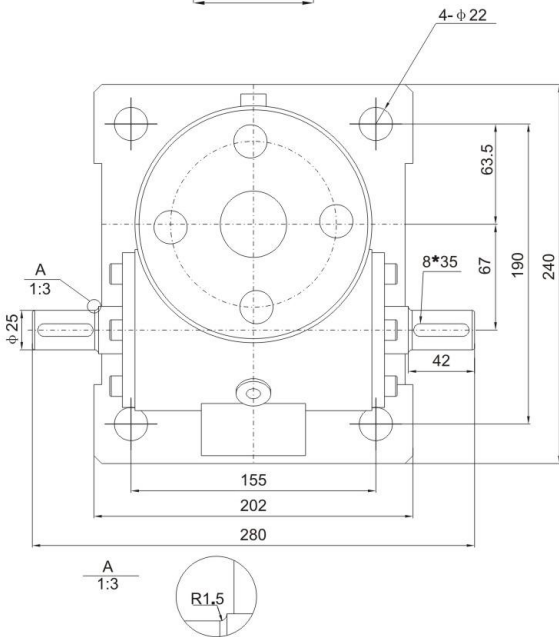
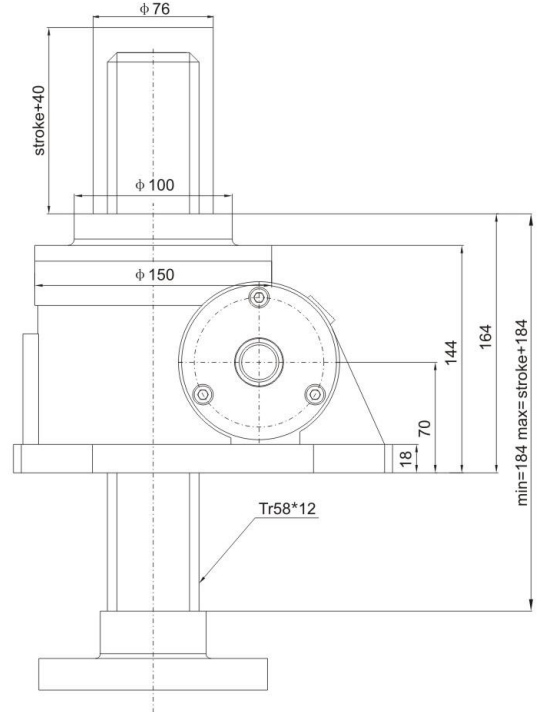

Screw head optional

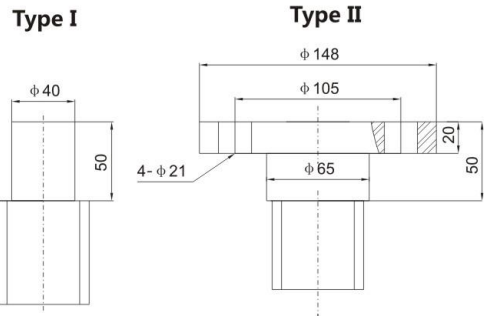

Type III



Type IV

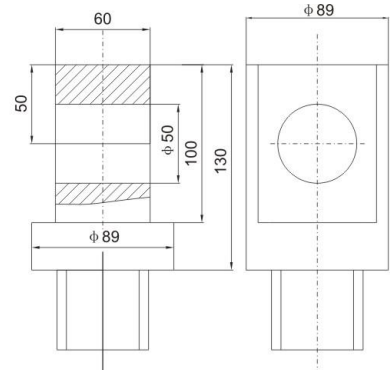

Shaft Direction

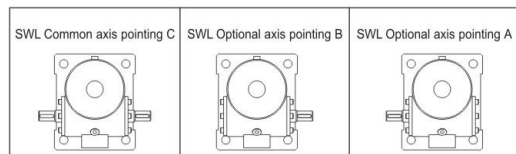



SWL20 type 1 structure (screw lifting type)

1A Upright translating screw

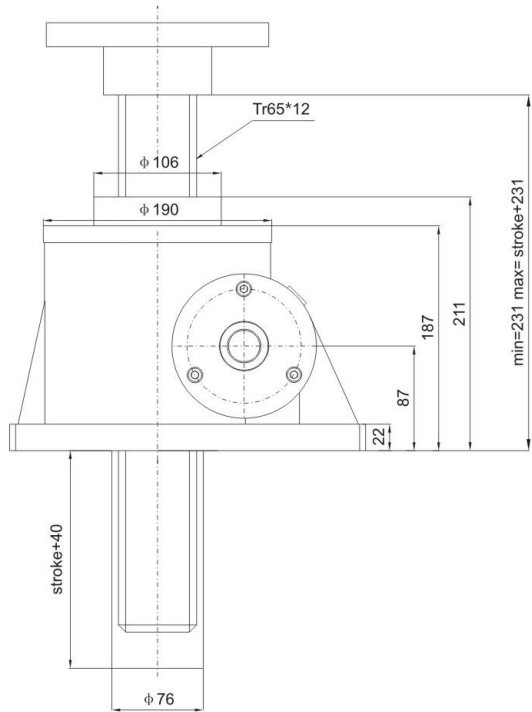

1B Inverted translating screw

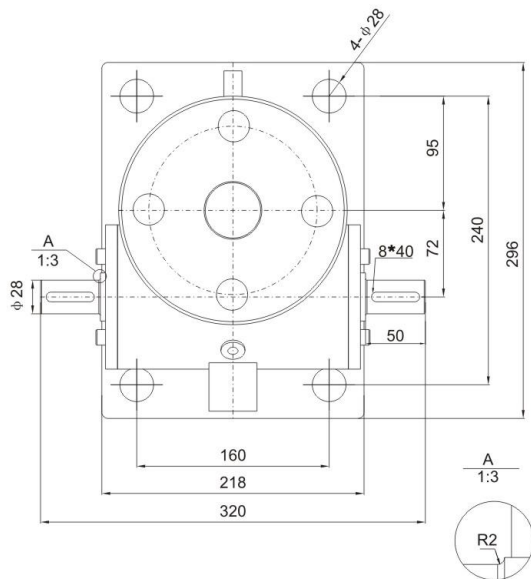
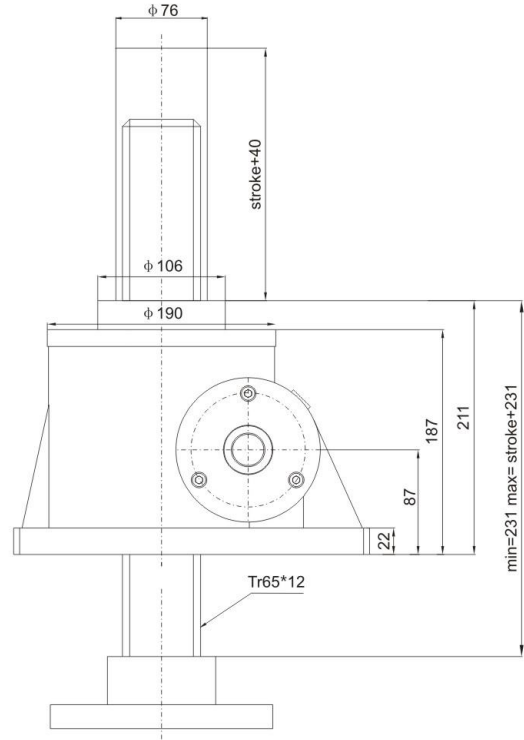

Screw head optional

Type I

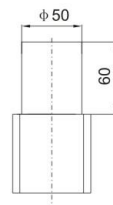

Type II

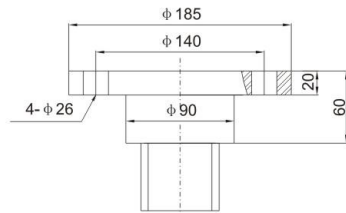

Type III

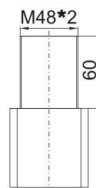

Type IV

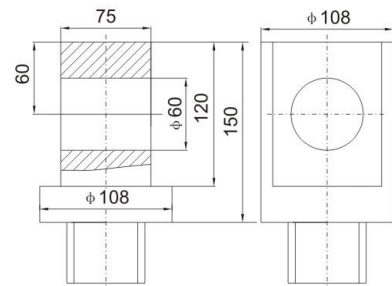

Shaft Direction

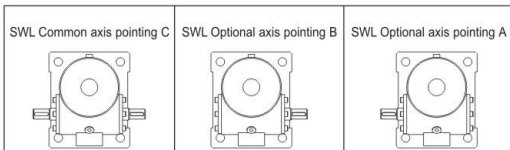



SWL25 type 1 structure (screw lifting type)

1A Upright translating screw

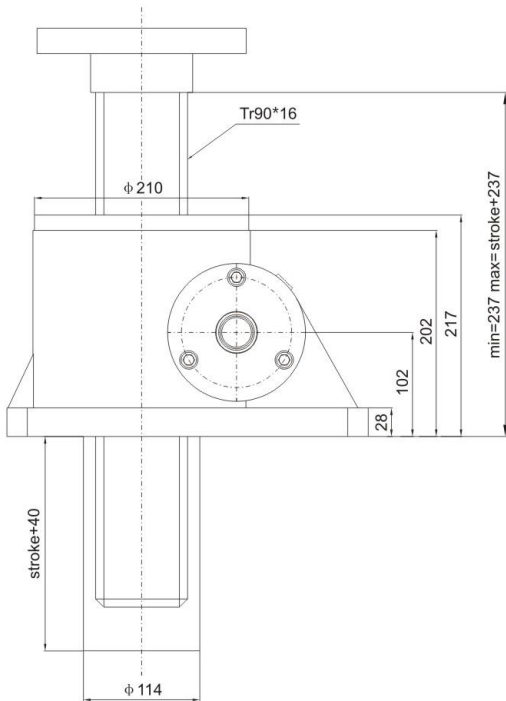

1B Inverted translating screw

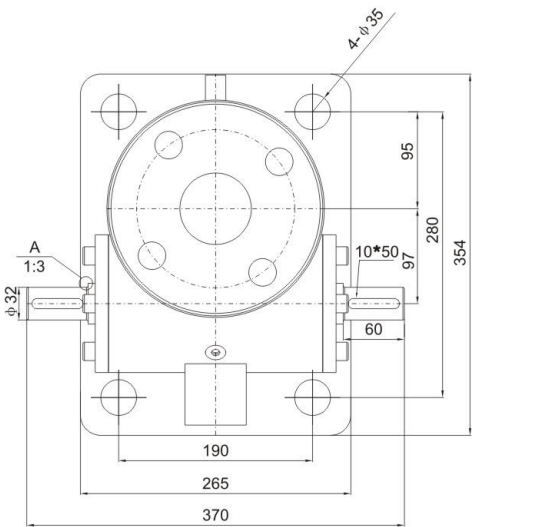
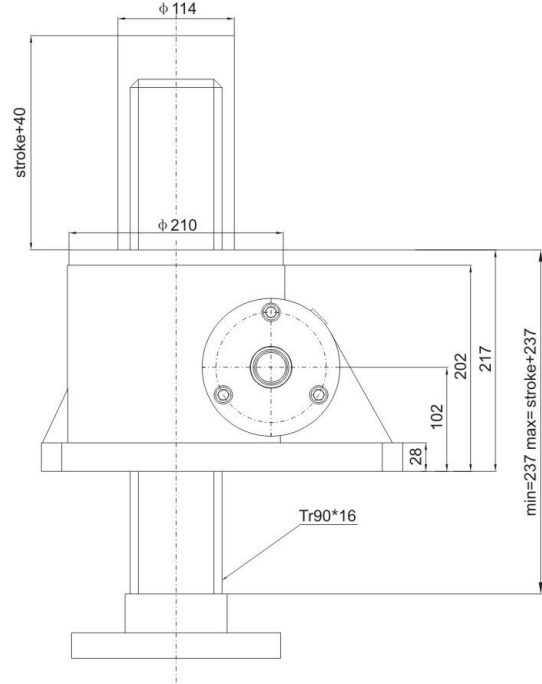

Screw head optional

Type I



Type II

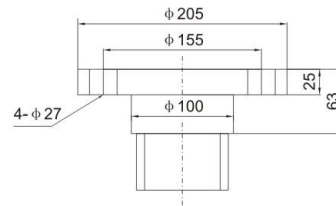

Type III

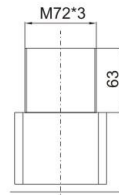

Type IV

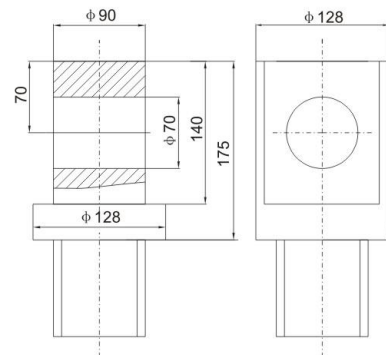

Shaft Direction

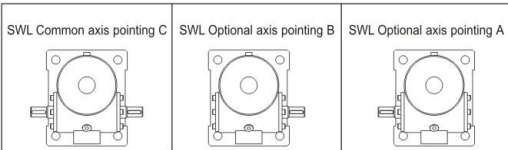



SWL35 type 1 structure (screw lifting type)

1A Upright translating screw

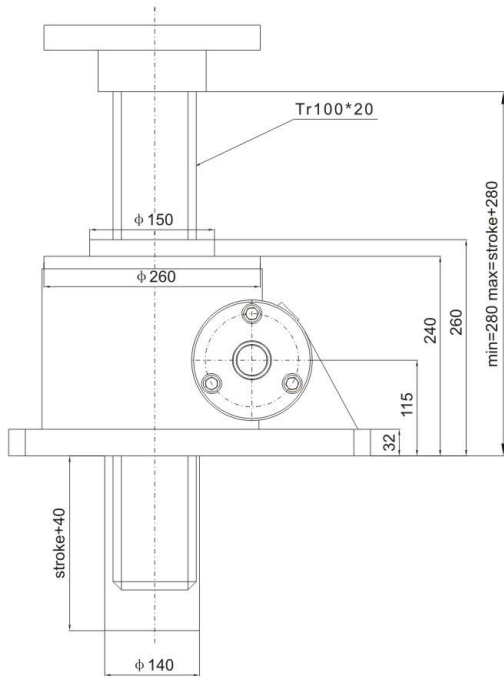

1B Inverted translating screw

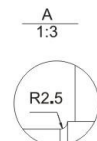
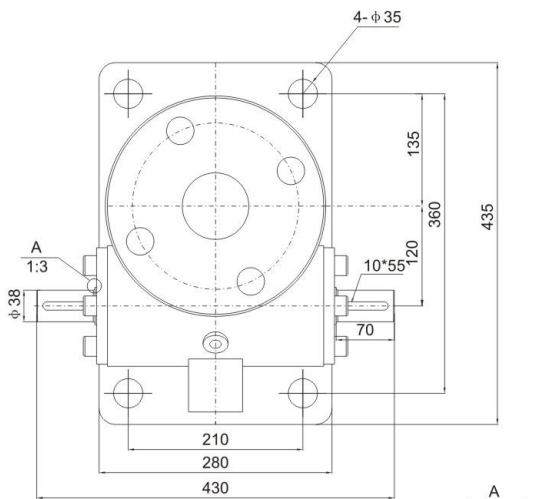
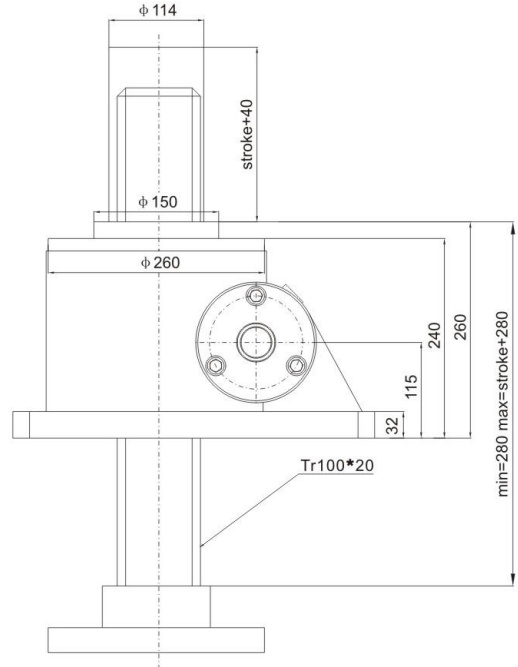

Screw head optional

Type I



Type II

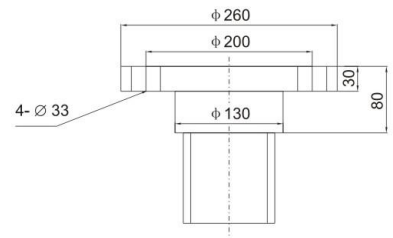

Type III



Type IV

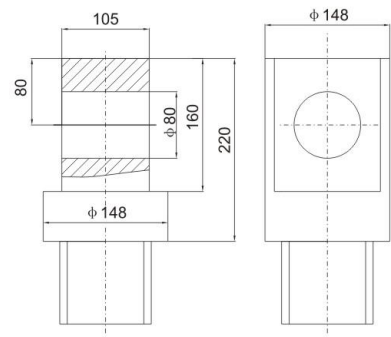

Shaft Direction

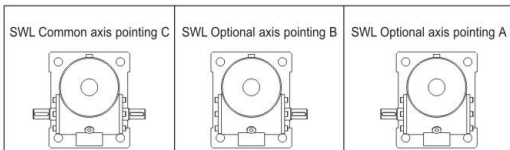



SWL50 type 1 structure (screw lifting type)

1A Upright translating screw

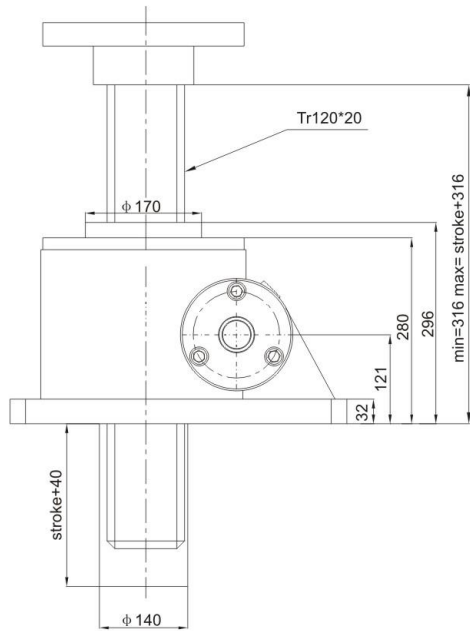

1B Inverted translating screw

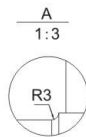
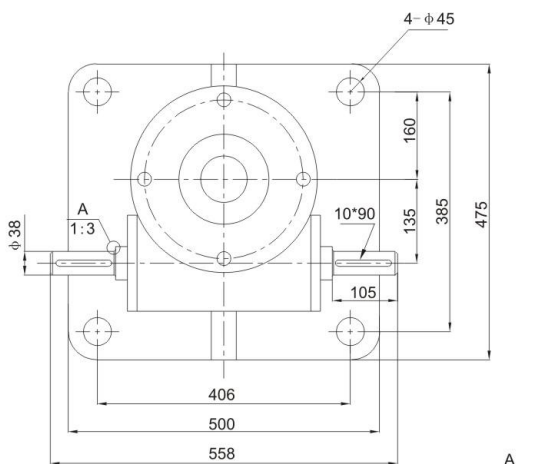
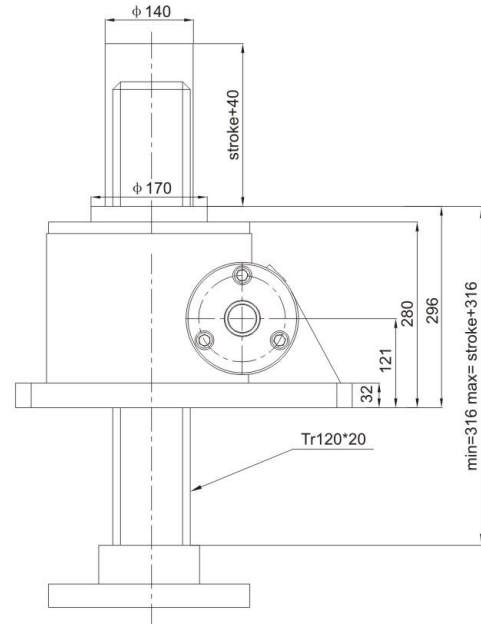

Screw head optional

Type I



Type II

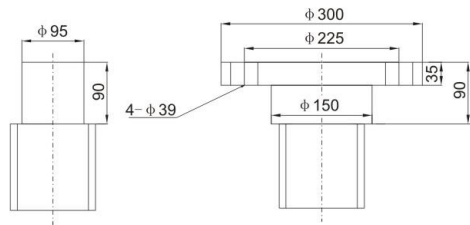

Type III

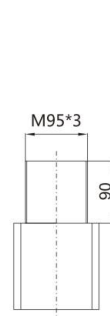

Type IV

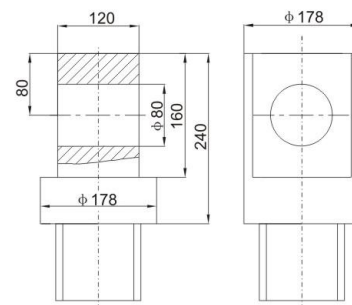

Shaft Direction

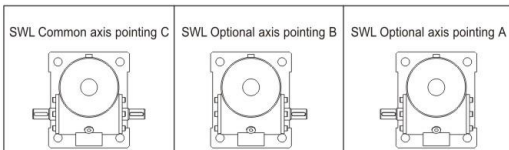



SWL100 type 1 structure (screw lifting type)

1A Upright translating screw

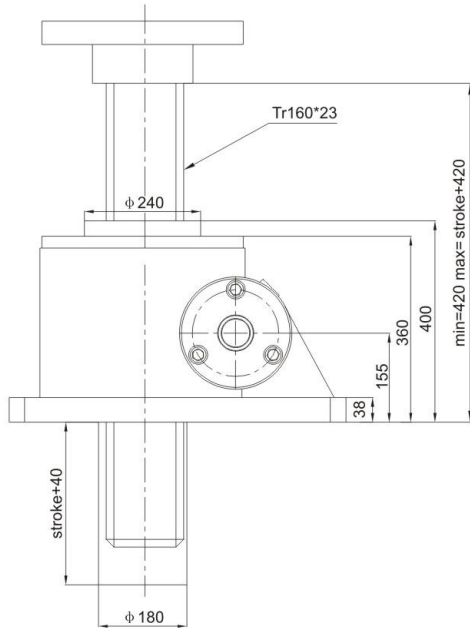

1B Inverted translating screw

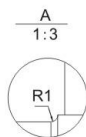
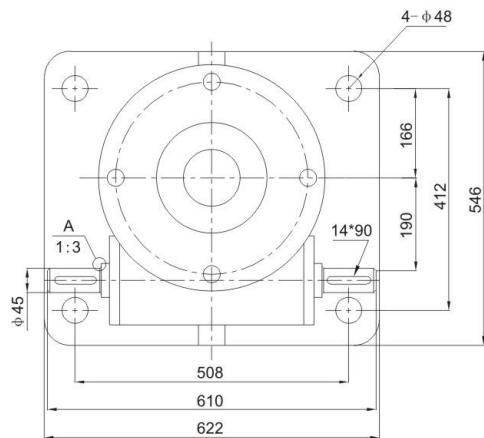
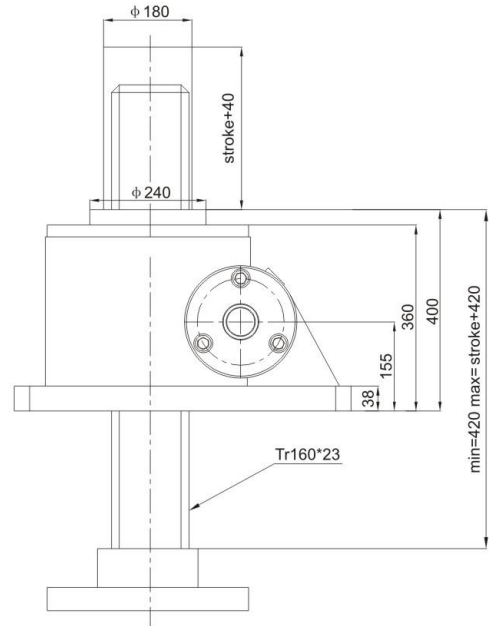

Screw head optional

Type I

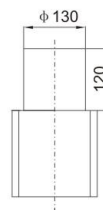

Type II

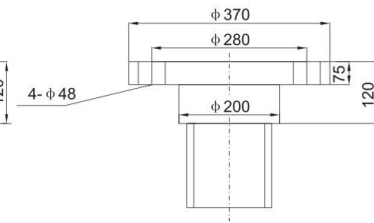

Type III

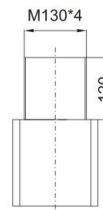

Type IV

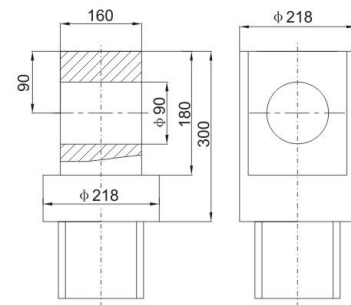

Shaft Direction

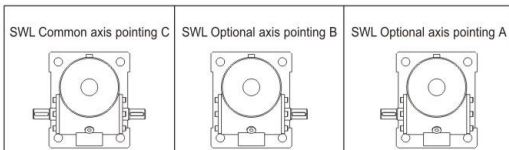



SWL120 type 1 structure (screw lifting type)

1A Upright translating screw

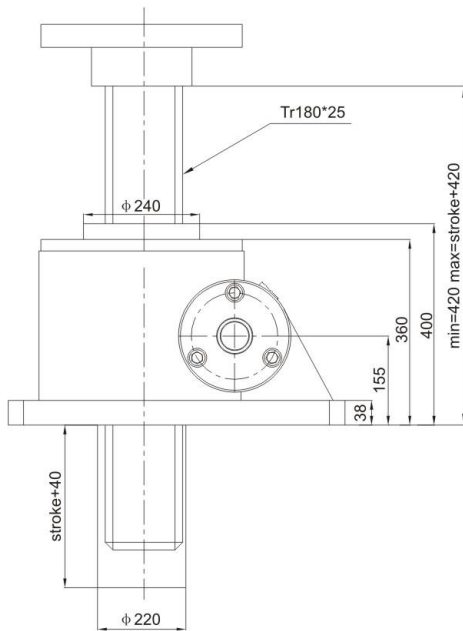

1B Inverted translating screw

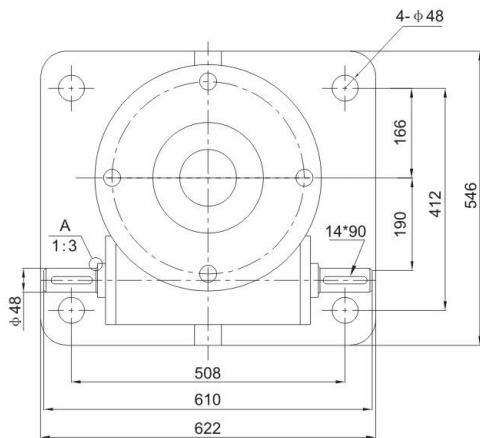
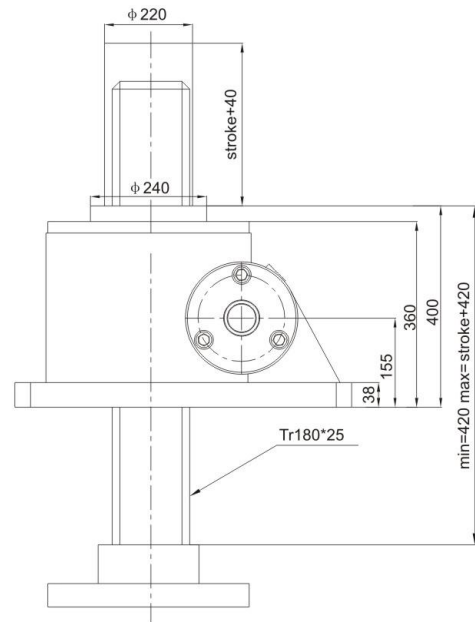

Screw head optional

Type I

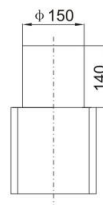

Type II

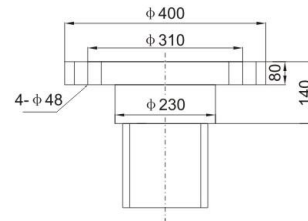

Type III

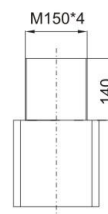

Type IV

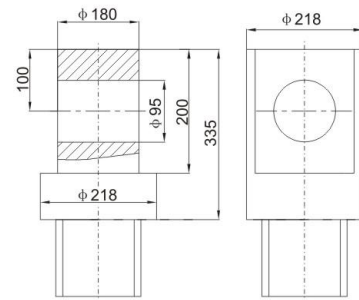

Shaft Direction

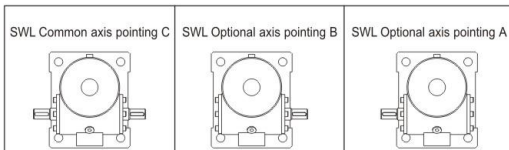

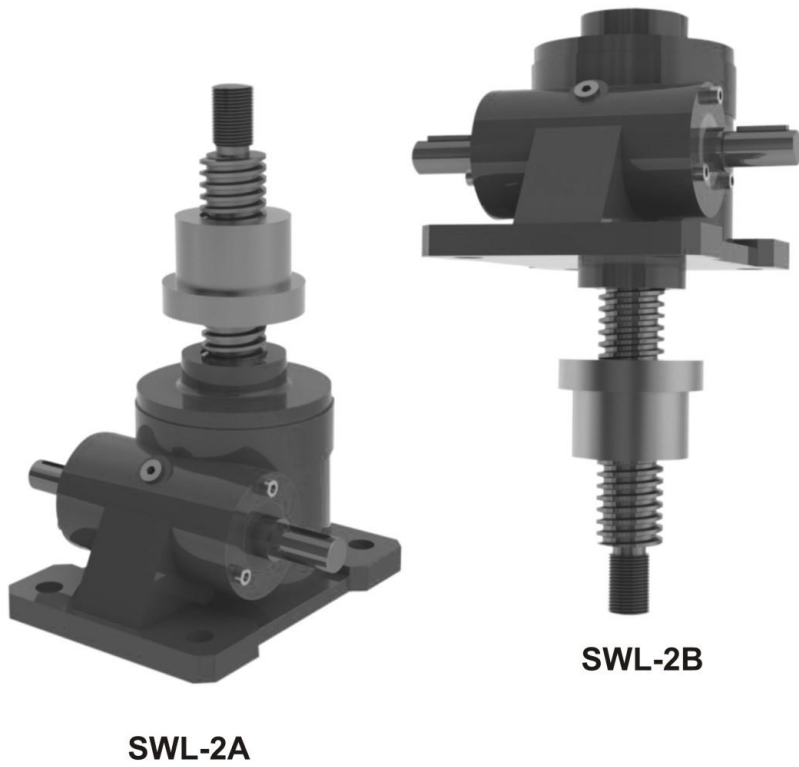

SWL-2B

SWL-2A

Example :

SWL 2.5 M - 2 A III - 300 - FZ - C
 1 2 3 4 5 6 7 8 9

1. SWL: serial number, SWL series - worm gear + T type screw lift; SWLB worm gear + ball screw lift;
 DSWL series - worm gear +T type screw elevator, with IEC motor interface type; DSWLB worm gear +ball screw elevator with IEC motor connection type;
2. 2.5: model, with the static load capacity of the lift as the model; mainly: 1, 2.5, 5, 10, 20, 25, 35, 50, 100, 120;
3. M: lifting speed, mainly refers to the deceleration ratio of worm gear pair; M: slow; P: fast;
4. 2: Structural model; Type 1: nut for rotary motion, screw for axial movement;
 Type 2: screw for rotary motion, nut for axial movement (products shown on this page are type I);
5. A: assembly type; type A: the screw (or nut) moves up (mounting surface); type B: the screw (or nut) moves down (mounting surface);
6. III: screw head type: 1 type screw head is divided into I type (cylindrical type), type II (flange type), type III (thread type), type IV (flat head type);
 2 type screw head is divided into I type (cylindrical type) and type III (thread type);
7. 300: lifting stroke; customer customization;
8. FZ: anti-rotation and protection of the screw;
 Type 1 structure has basic type, anti-rotation type (F-key anti-rotation) and protective cover type(Z steel pipe protection - passive side, X telescopic tube protection - active side, Q both);
 Type 2 structure has basic type and protective cover type (X telescopic tube protection - active side);
9. C: the axis points to A; B; C; D; E;



SWL1 type 2 construction (nut lifting)

2A Upright rotating screw

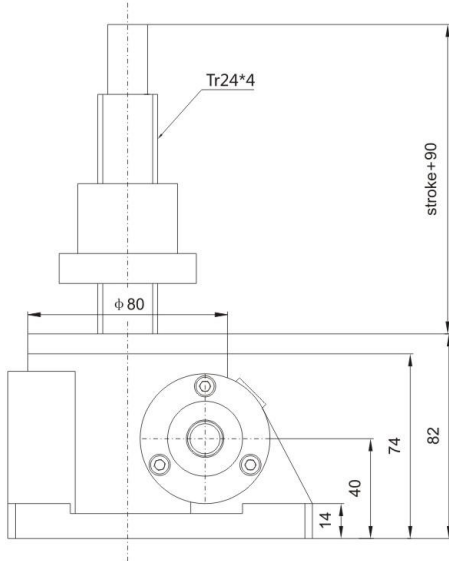

2B Inverted rotating screw

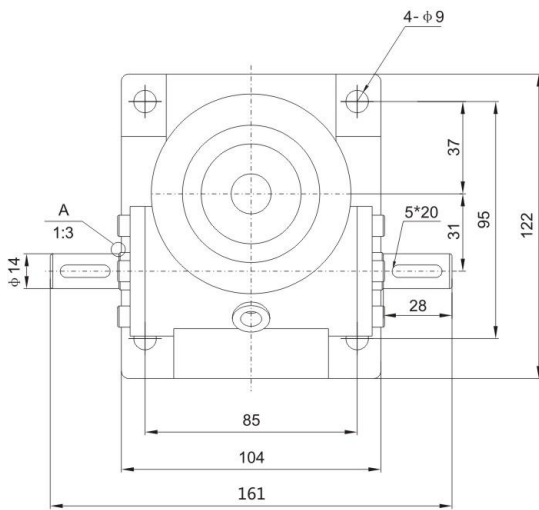
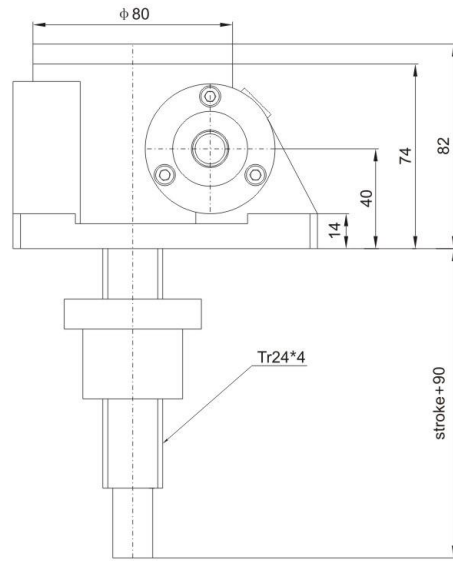

A
1:3



Screw head optional

Type I



Type III

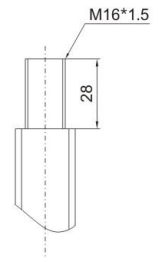

Type 2 screw nut

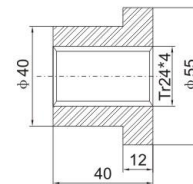

Shaft Direction

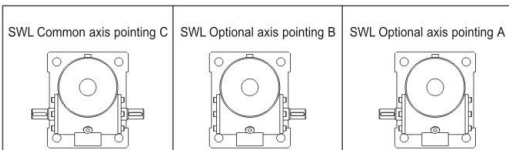



LINEAR MOTION

SWL2.5 type 2 construction (nut lifting)

2A Upright rotating screw

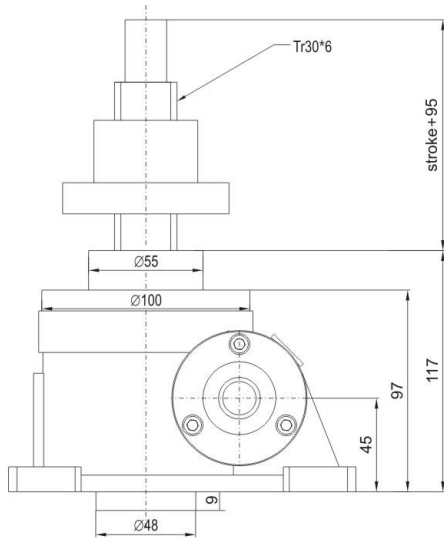

2B Inverted rotating screw

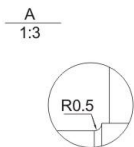
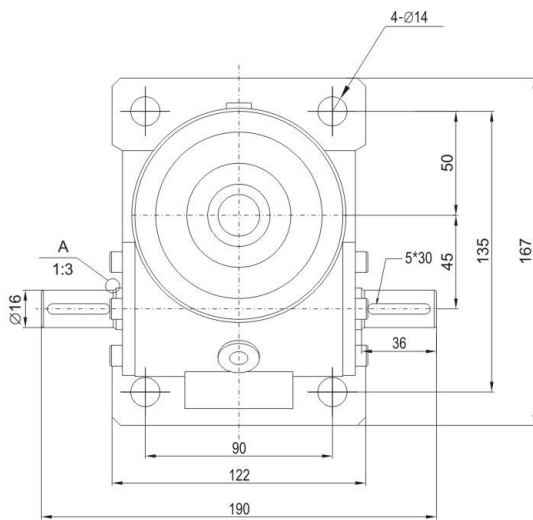
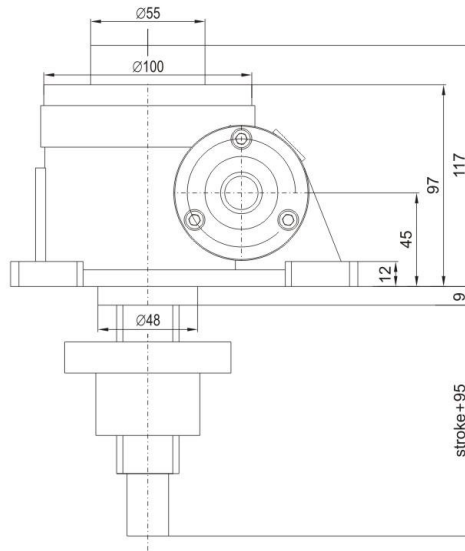

Screw head optional

Type I

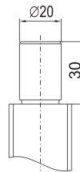

Type III



Type 2 screw nut

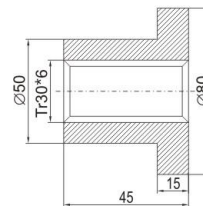

Shaft Direction

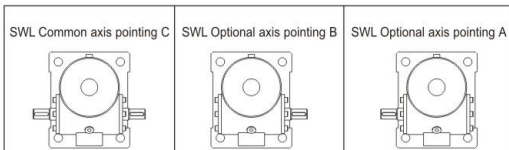



SWL5 type 2 construction (nut lifting)

2A Upright rotating screw

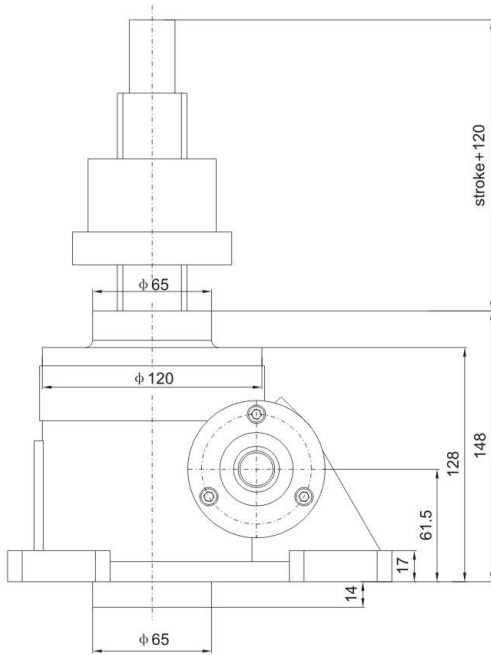

2B Inverted rotating screw

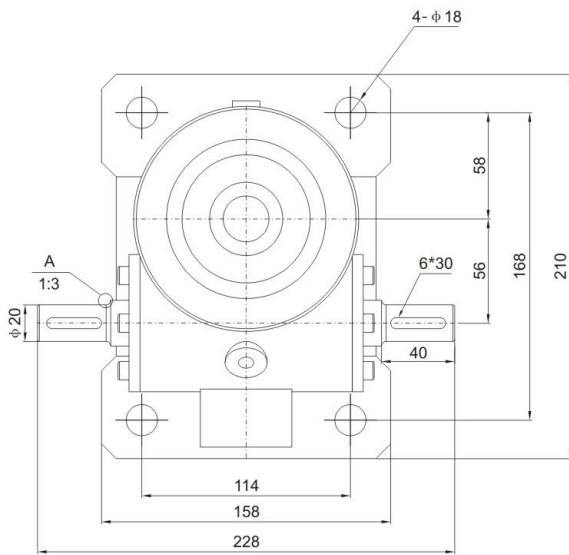
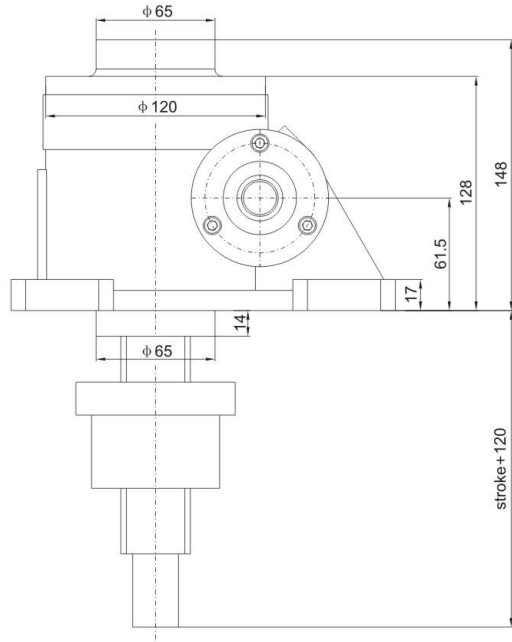

Screw head optional

Type I

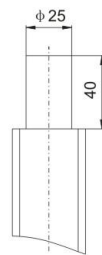

Type III

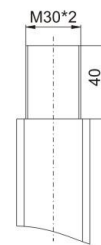

Type 2 screw nut

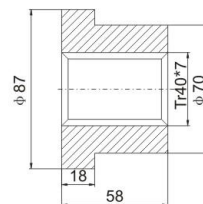

Shaft Direction

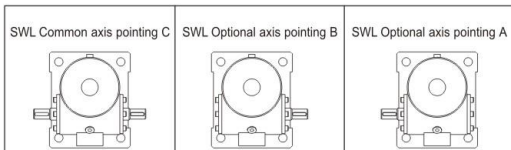



LINEAR MOTION

SWL10 type 2 construction (nut lifting)

2A Upright rotating screw

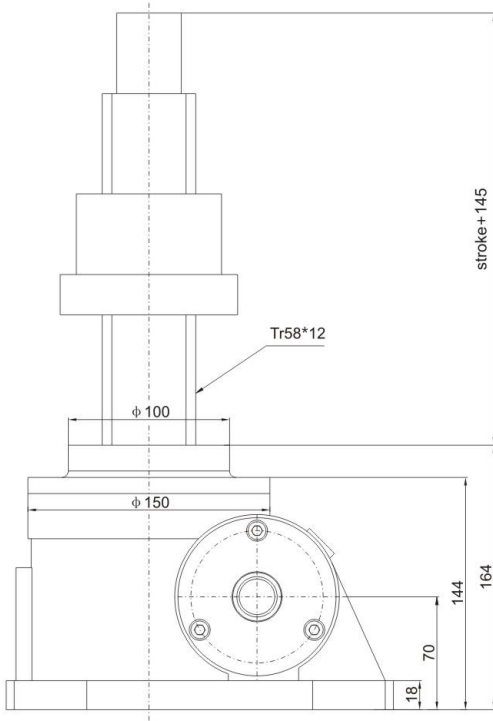

2B Inverted rotating screw

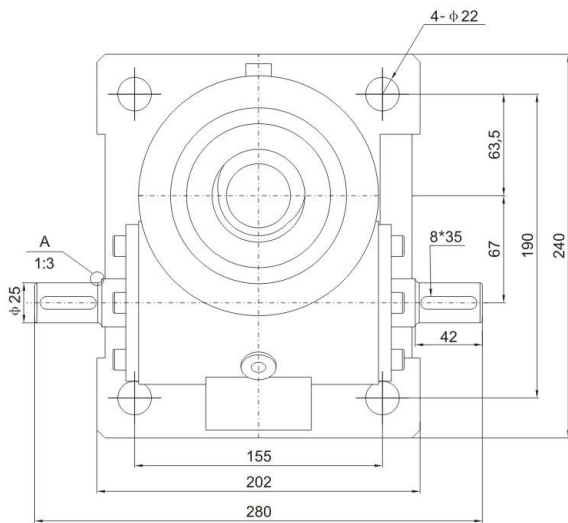
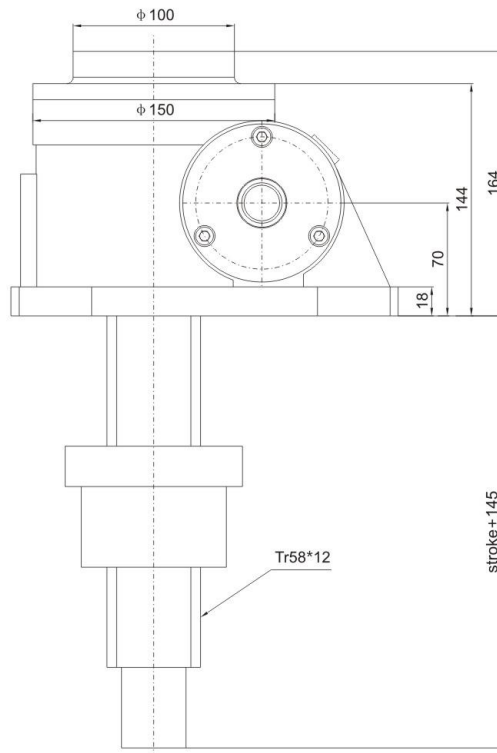

Screw head optional

Type I



Type III



A 1:3



Shaft Direction

SWL Common axis pointing C	SWL Optional axis pointing B	SWL Optional axis pointing A

Type 2 screw nut

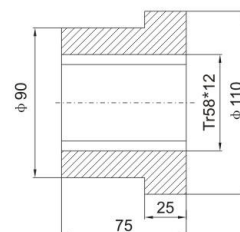



LINEAR MOTION

SWL20 type 2 construction (nut lifting)

2A Upright rotating screw

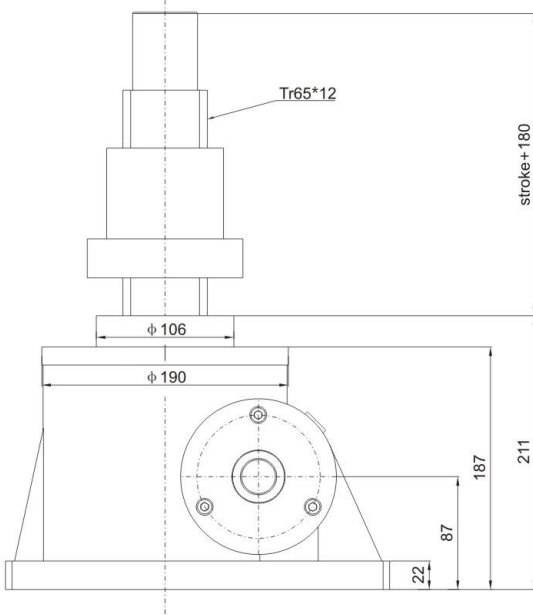

2B Inverted rotating screw

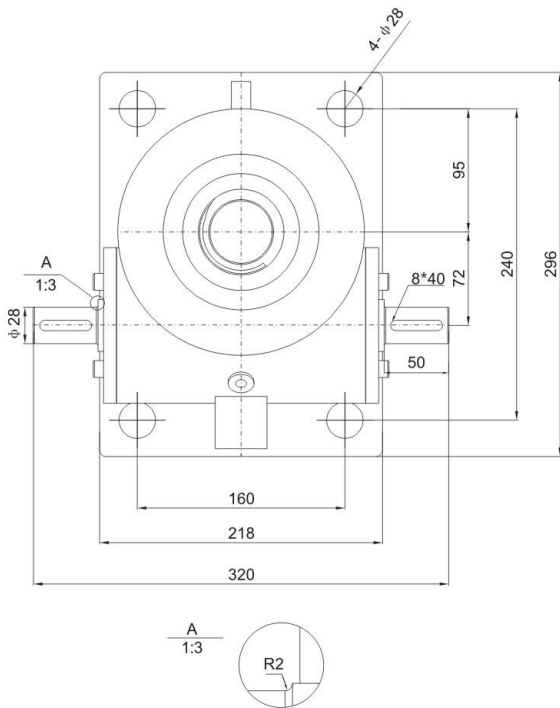
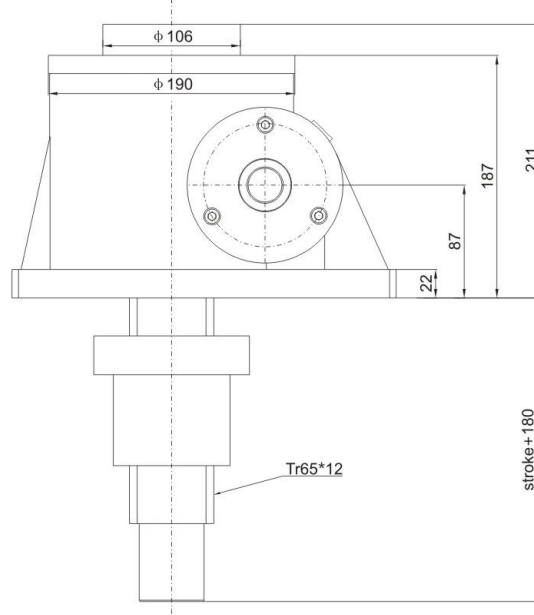

Screw head optional

Type I

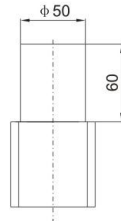

Type III

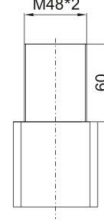

Type 2 screw nut

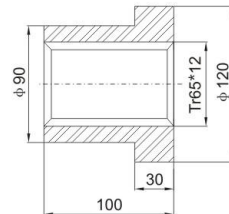

Shaft Direction

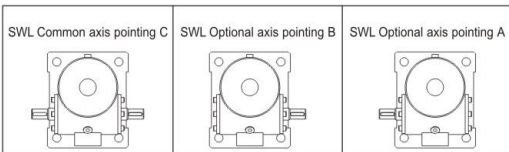



LINEAR MOTION

SWL25 type 2 construction (nut lifting)

2A Upright rotating screw

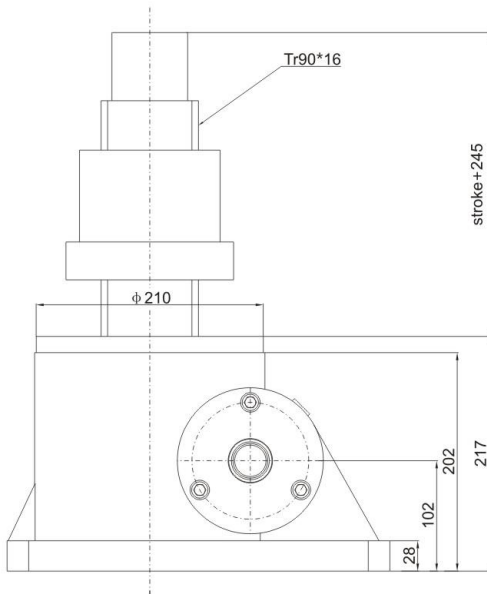

2B Inverted rotating screw

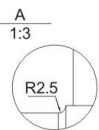
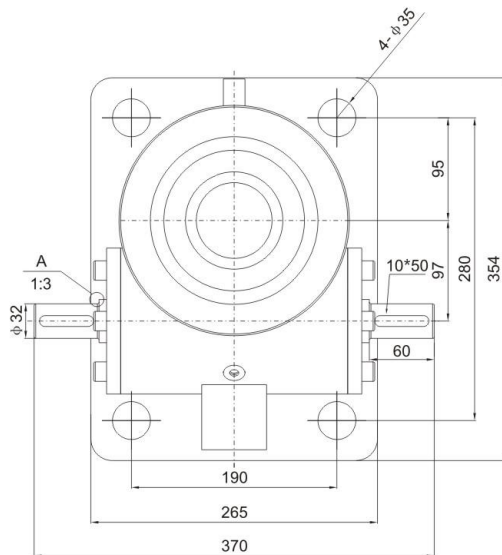
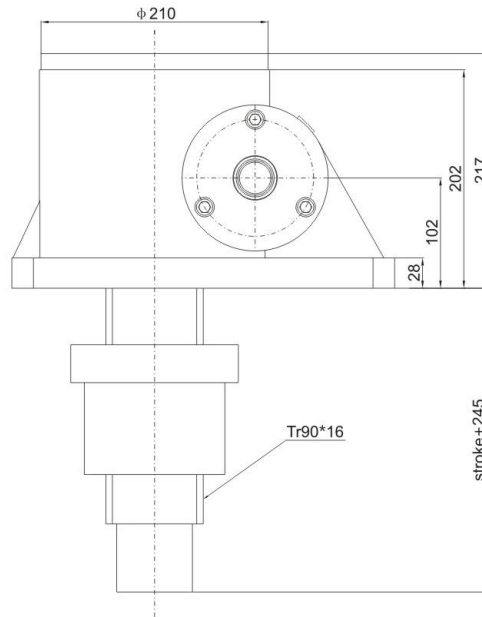

Screw head optional

Type I



Type III

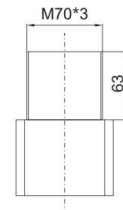

Type 2 screw nut

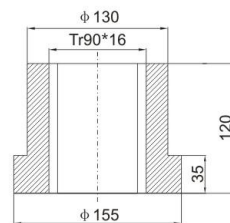

Shaft Direction

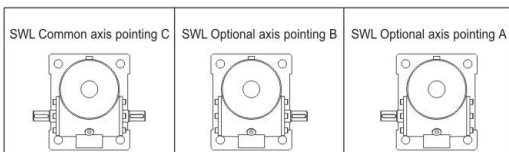



SWL35 type 2 construction (nut lifting)

2A Upright rotating screw

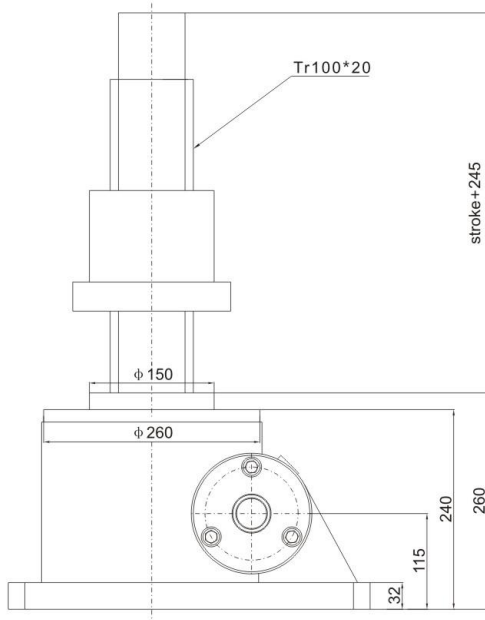

2B Inverted rotating screw

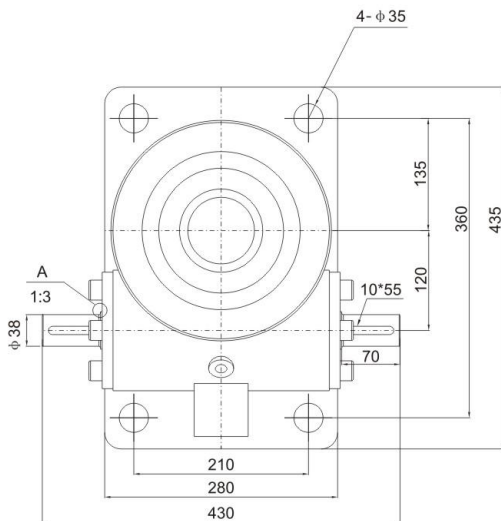
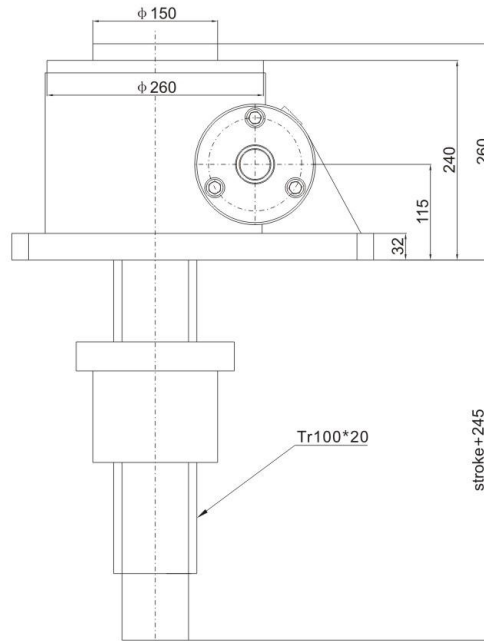

Screw head optional

Type I

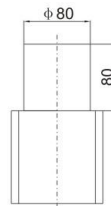

Type III



Type 2 screw nut

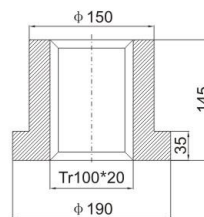

A
1:3



Shaft Direction

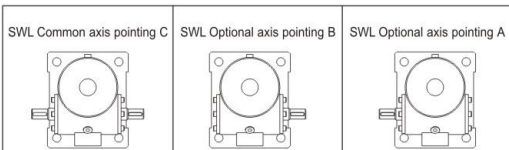



SWL50 type 2 construction (nut lifting)

2A Upright rotating screw

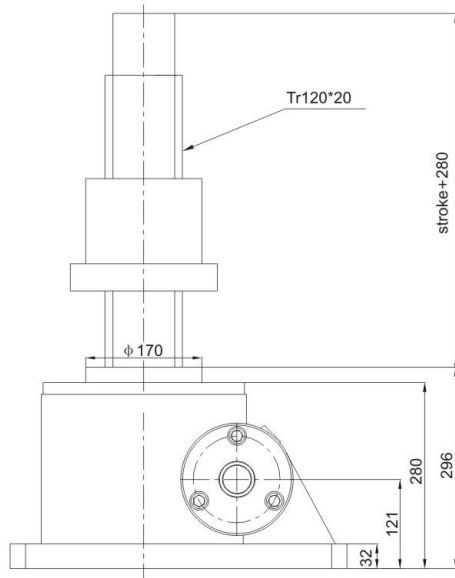

2B Inverted rotating screw

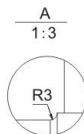
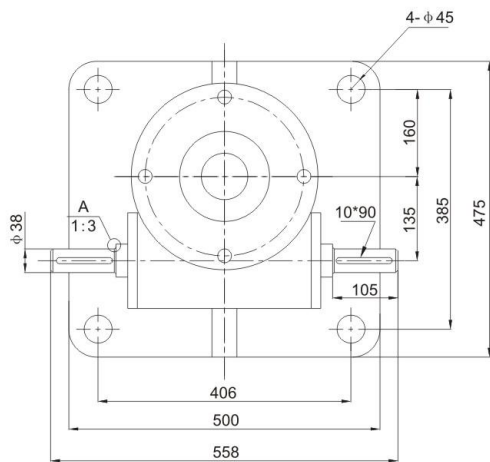
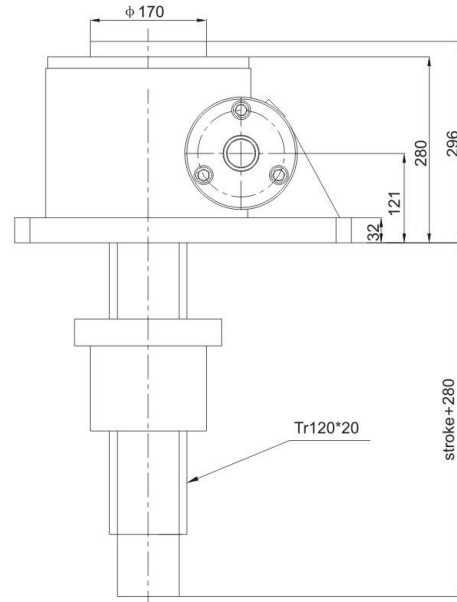

Screw head optional

Type I



Type III



Type 2 screw nut

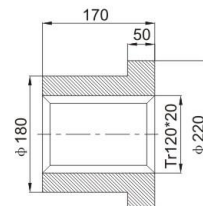

Shaft Direction

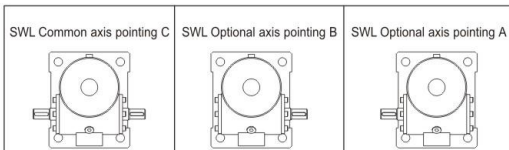



SWL100 type 2 construction (nut lifting)

2A Upright rotating screw

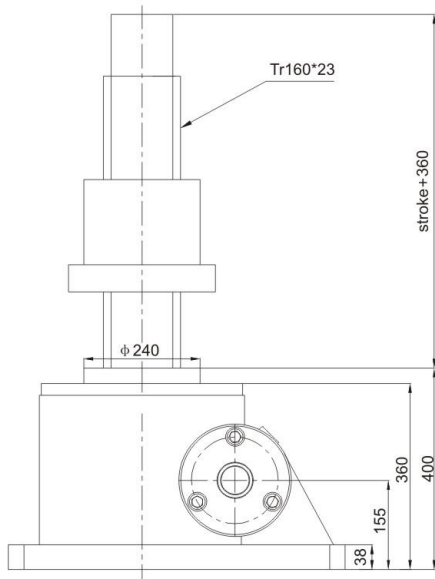

2B Inverted rotating screw

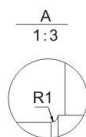
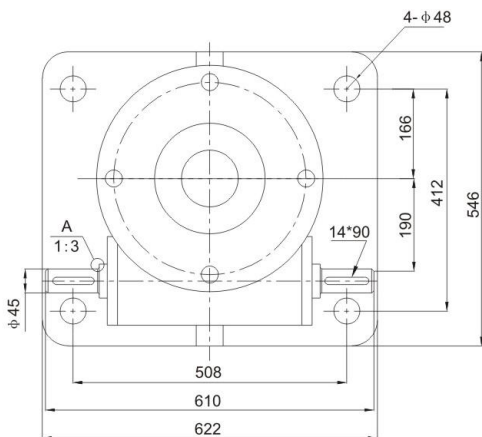
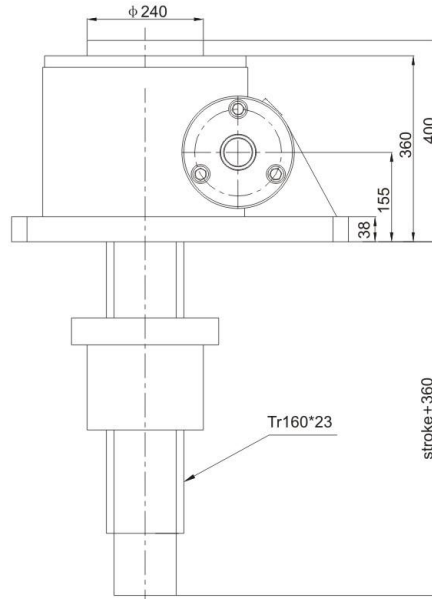

Screw head optional

Type I



Type III

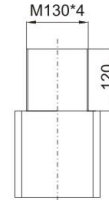

Type 2 screw nut

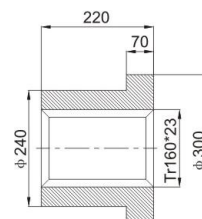

Shaft Direction

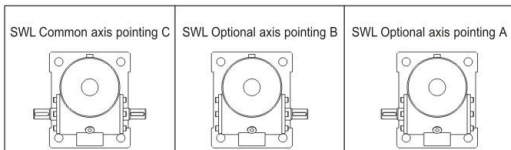



LINEAR MOTION

SWL120 type 2 construction (nut lifting)

2A Upright rotating screw

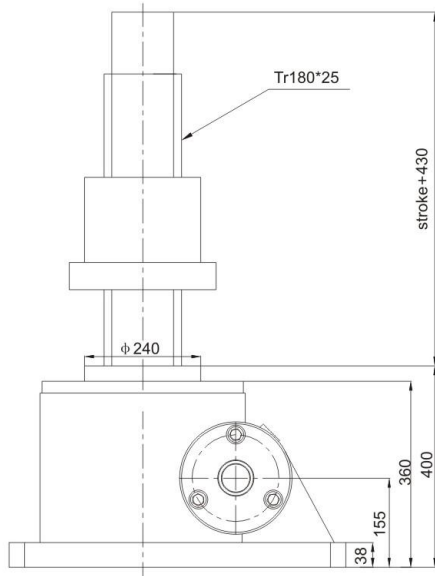

2B Inverted rotating screw

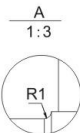
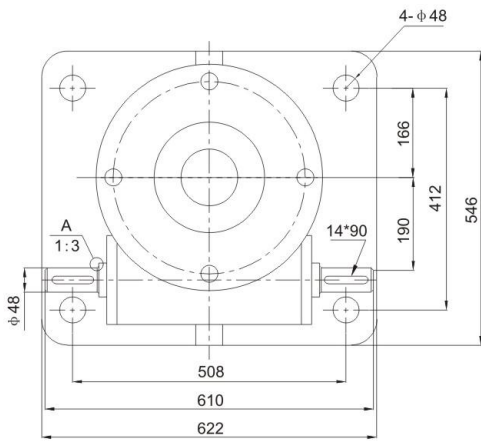
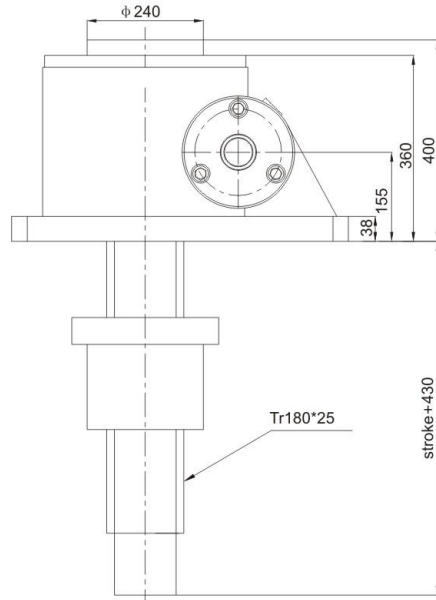

Screw head optional

Type I

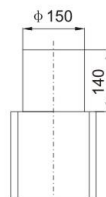

Type III

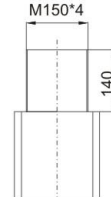

Type 2 screw nut

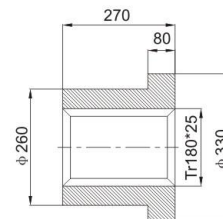

Shaft Direction

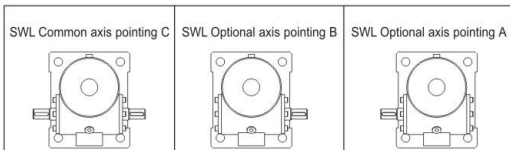



SWLB series ball screw lifting

Basic type 1A

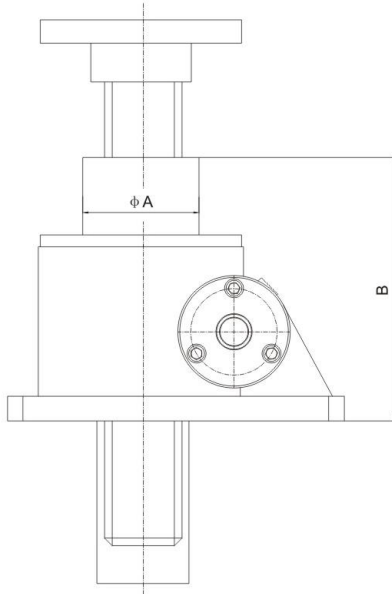

Basic type 1B

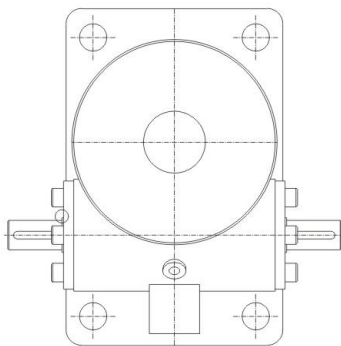
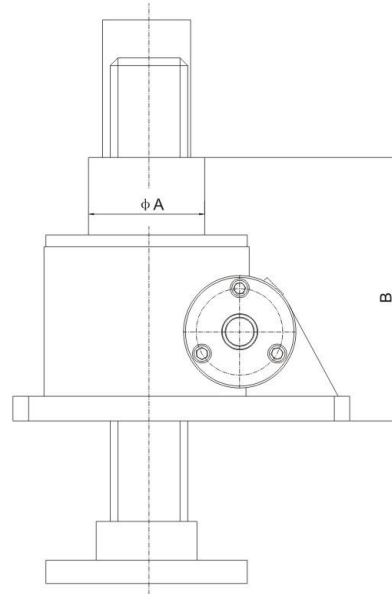

SWLB series	A	B	Shaft diameter × lead	Dynamic load	Static load
SWLB 2.5	80	123	2508	7.5kgf	22.8kgf
SWLB 5	95	210	4010	9.7kgf	22.8kgf
SWLB 10	125	226	5516	22.5kgf	70kgf
SWLB 20	135	231.5	6516	22.5kgf	70kgf

Shaft Direction

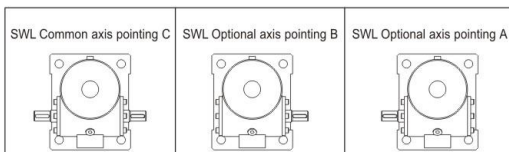



SWLB series ball screw lifting

Basic type 2A

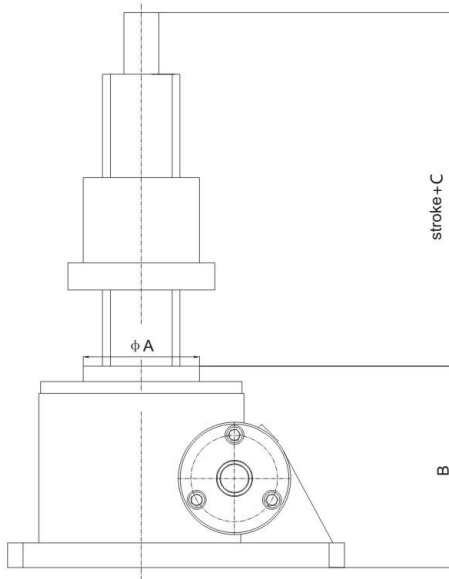

Basic type 2B

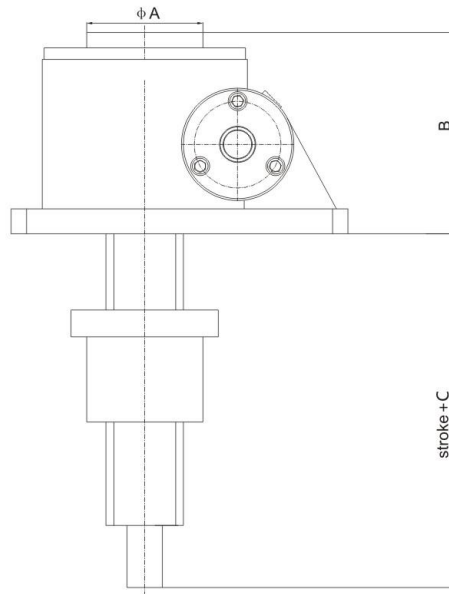

Ball screw nut

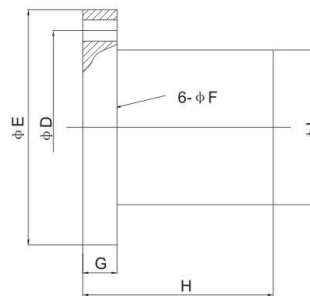
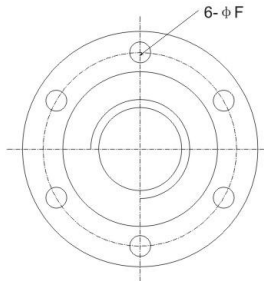
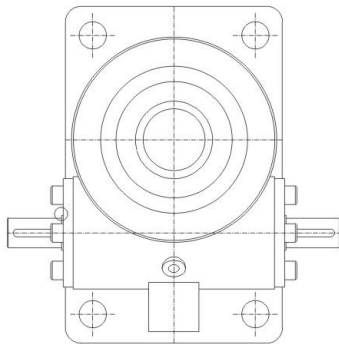

SWLB series	A	B	C	D	E	F	G	H	I	Shaft diameter x lead	Dynamic load	Static load
SWLB 2.5	55	117	128.5	77	86	7	13	80	56	2508	7.5kgf	22.8kgf
SWLB 5	65	148	128.5	105	128	11	18	103	85	4010	9.7kgf	22.8kgf
SWLB 10	100	164	128.5	125	152	13.5	22	123	100	5010	22.5kgf	70kgf
SWLB 20	106	211	128.5	140	166	13.5	22	123	118	6310	22.5kgf	70kgf

Shaft Direction

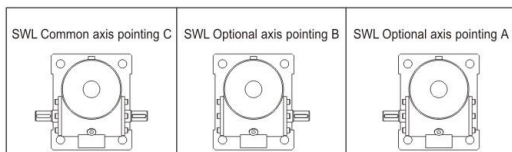



DSWL+IEC motor input flange module combination

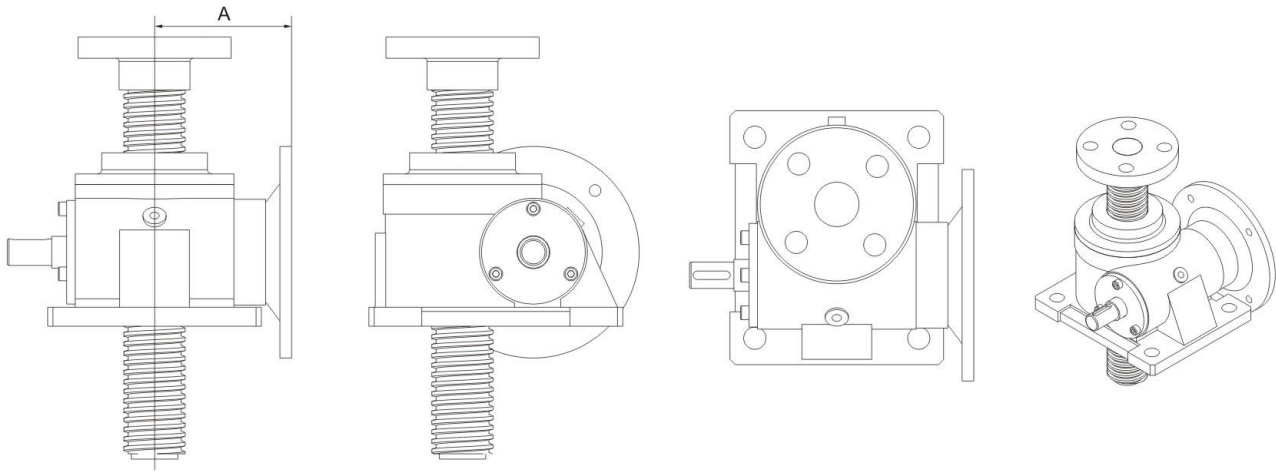

DSWL series model	+	Optional IEC motor flange type				A
DSWL1	+	63B5	63B14			70.5
DSWL2.5	+	71B5	71B14	80B5	80B14	77/85
DSWL5	+	80B5	80B14	90B5	90B14	3.99
DSWL10	+	90B5	90B14	100B5	100B14	117.5/152.5
DSWL20	+	100B5	100B14	112B5	112B14	145.5

DSWL 2.5 M - 2 A III - 300 - FZ - C + 71B5
 1 2 3 4 5 6 7 8 9 10

- DSWL: DSWL series - worm gear +T type screw elevator, with IEC motor interface type; DSWLB worm gear + ball screw elevator with IEC motor connection type;
- 2.5: model, with the static load capacity of the lift as the model; mainly: 1, 2.5, 5, 10, 20, 25, 35, 50, 100, 120;
- M: lifting speed, mainly refers to the deceleration ratio of worm gear pair; M: slow; P: fast;
- 2: Structural model; Type 1: nut for rotary motion, screw for axial movement;
 Type 2: screw for rotary motion, nut for axial movement (products shown on this page are type I);
- A: assembly type; type A: the screw (or nut) moves up (mounting surface); type B: the screw (or nut) moves down (mounting surface);
- III: screw head type: 1 type screw head is divided into I type (cylindrical type), type II (flange type), type III (thread type), type IV (flat head type);
 2 type screw head is divided into I type (cylindrical type) and type III (thread type);
- 300: lifting stroke; customer customization;
- FZ: anti-rotation and protection of the screw;
 Type 1 structure has basic type, anti-rotation type (F-key anti-rotation) and protective cover type(Z steel pipe protection - passive side, X telescopic tube protection - active side, Q both);
 Type 2 structure has basic type and protective cover type (X telescopic tube protection - active side);
- C: the axis points to A; B; C; D; E;
- 71B5: IEC input connector model;

Shaft direction

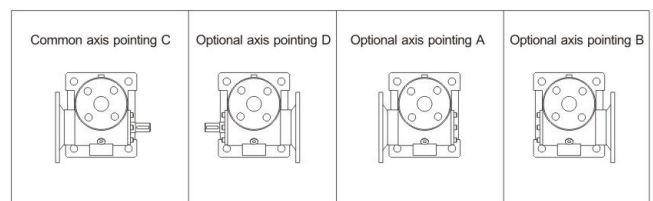



SWL+RV module combination

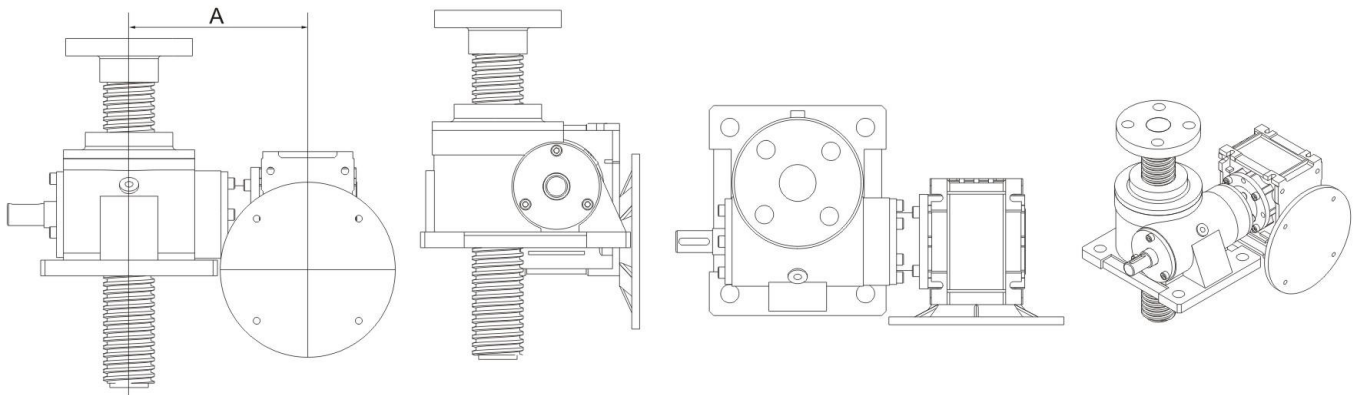

SWL series model	+	RV series model	+	Optional input flange type						A
SWL1	+	RV30	+	56B5	56B14	63B5	63B14			113.5
SWL2.5	+	RV40	+	56B5	56B14	63B5	63B14	71B5	71B14	128.5
SWL5	+	RV50	+	63B5	63B14	71B5	71B14	80B5	80B14	144.5
SWL10	+	RV63	+	71B5	71B14	80B5	80B14	90B5	90B14	198.5
SWL20	+	RV63	+	71B5	71B14	80B5	80B14	90B5	90B14	230

SWL 2.5 M - 1 A II - 300 - FZ - C + RV40 - 10 - 71B14

1 2 3 4 5 6 7 8 9 10 11 12

1. SWL: serial number, SWL series - worm gear + T type screw lift; SWLB worm gear + ball screw lift;
2. 2.5: model, with the static load capacity of the lift as the model; mainly: 1, 2.5, 5, 10, 20, 25, 35, 50, 100, 120;
3. M: lifting speed, mainly refers to the deceleration ratio of worm gear pair; M: slow; P: fast;
4. 1: Structural model; Type 1: nut for rotary motion, screw for axial movement (products shown on this page are type I);
Type 2: screw for rotary motion, nut for axial movement;
5. A: assembly type; type A: the screw (or nut) moves up (mounting surface); type B: the screw (or nut) moves down (mounting surface);
6. III: screw head type: 1 type screw head is divided into I type (cylindrical type), type II (flange type), type III (thread type), type IV (flat head type);
2 type screw head is divided into I type (cylindrical type) and type III (thread type);
7. 300: lifting stroke; customer customization;
8. FZ: anti-rotation and protection of the screw;
Type 1 structure has basic type, anti-rotation type (F-key anti-rotation) and protective cover type (Z steel pipe protection - passive side, X telescopic tube protection - active side, Q both);
Type 2 structure has basic type and protective cover type (X telescopic tube protection - active side);
9. C: the axis points to A; B; C; D; E;
10. RV40: input reducer with RV series;
11. 10: reduction ratio of RV series reducer;
12. 71B14: RV series reducer input contact type;

Shaft direction

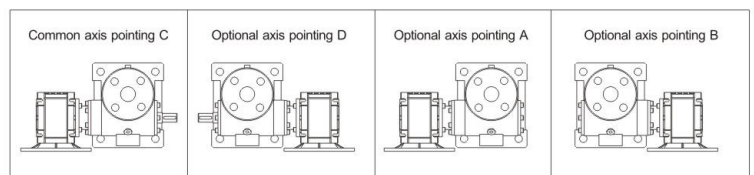



LINEAR MOTION

SWL+PC module combination

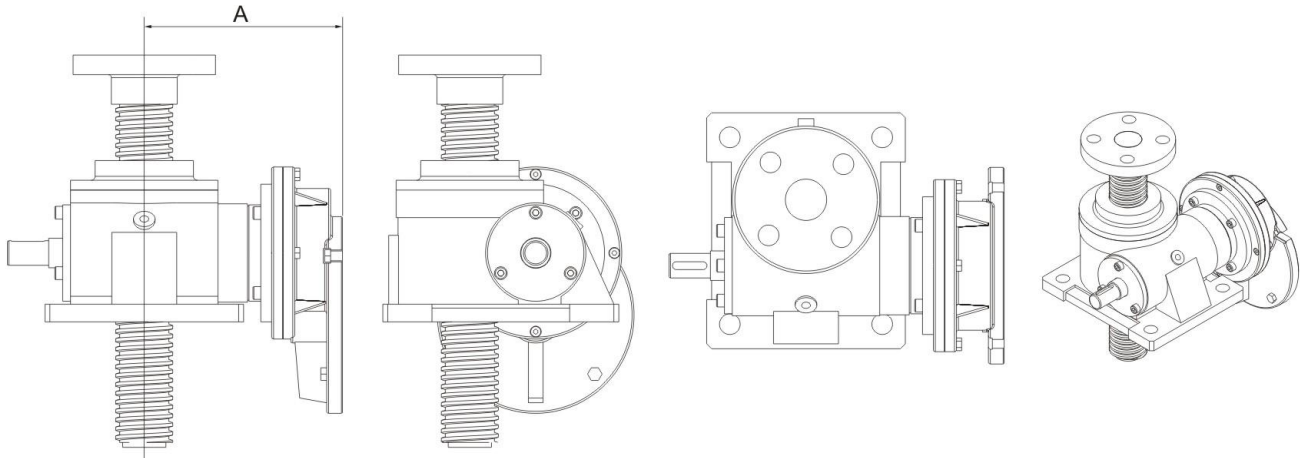

SWL series model	+	PC series model	PC reduction ratio	A
SWL1	+	PC63B5	i=2.93	128.5
SWL2.5	+	PC71B5	i=2.94	142
SWL5	+	PC80B5	i=3	175.5
SWL10	+	PC90B5	i=2.45	202
SWL20	+	PC90B5	i=2.45	223

SWL 2.5 M - 1 A II - 300 - FZ - C + PC71B5
 1 2 3 4 5 6 7 8 9 10

1. SWL: serial number, SWL series - worm gear + T type screw lift; SWLB worm gear + ball screw lift;
2. 2.5: model, with the static load capacity of the lift as the model; mainly: 1, 2.5, 5, 10, 20, 25, 35, 50, 100, 120;
3. M: lifting speed, mainly refers to the deceleration ratio of worm gear pair; M: slow; P: fast;
4. 1: Structural model; Type 1: nut for rotary motion, screw for axial movement (products shown on this page are type I);
Type 2: screw for rotary motion, nut for axial movement;
5. A: assembly type; type A: the screw (or nut) moves up (mounting surface); type B: the screw (or nut) moves down (mounting surface);
6. II: screw head type: 1 type screw head is divided into I type (cylindrical type), type II (flange type), type III (thread type), type IV (flat head type);
2 type screw head is divided into I type (cylindrical type) and type III (thread type);
7. 300: lifting stroke; customer customization;
8. FZ: anti-rotation and protection of the screw;
Type 1 structure has basic type, anti-rotation type (F-key anti-rotation) and protective cover type (Z steel pipe protection - passive side, X telescopic tube protection - active side, Q both);
Type 2 structure has basic type and protective cover type (X telescopic tube protection - active side);
9. C: the axis points to A; B; C; D; E;
10. PC71B5: model of primary gear PC;

Shaft direction

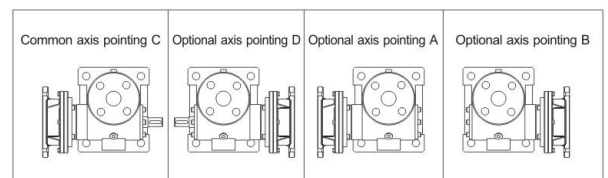



LINEAR MOTION

Dezhou Lude Transmission Equipments CO.,LTD

NO.2758 Mengyin Road, Economic&Technical Development Zone, Dezhou, Shandong, China

TEL: 0086-534-2765998 2761998

E-mail: ludetransmission@gmail.com china@ludetransmission.com

Web: www.ludetransmission.com